

Model 1313B VXibus Microwave Downconverter

Operation Manual

CCN 12001,12002

Manual Assy. Part Number: 5585498-01
Manual Text Part Number: 5580498-01
Printed in USA, January 2011

WARRANTY

Phase Matrix, Inc. warrants this product to be free from defects in material and workmanship for one year from the date of delivery. Damage due to accident, abuse, or improper signal level is not covered by the warranty. Removal, defacement, or alteration of any serial or inspection label, marking, or seal may void the warranty. Phase Matrix, Inc. will repair or replace, at its option, any components of this product which prove to be defective during the warranty period, provided the entire unit is returned to Phase Matrix, Inc. or an authorized service facility. In-warranty units will be returned freight prepaid; out-of-warranty units will be returned freight COLLECT. No warranty other than the above is expressed or implied.

CERTIFICATION

Phase Matrix, Inc. certifies this instrument to be in conformance with the specifications noted herein at time of shipment from the factory. Phase Matrix, Inc. further certifies that its calibration measurements are traceable to the United States National Institute of Standards and Technology.

MANUAL CHANGE INFORMATION

As Phase Matrix, Inc. continually improves and updates its products, changes to the material covered by the manual will occur. When a part or assembly in an Phase Matrix, Inc. instrument is changed to the extent that it is no longer interchangeable with the earlier part, the configuration control number (CCN) of the instrument, shown on the title page of the manual, will change, and a new edition of the manual will be published.

To maintain the technical accuracy of the manual, it may be necessary to provide new or additional information with the manual. In these cases, the manual is shipped with a Manual Update. Please be sure to incorporate the information as instructed in the Manual Update.

CONTACTING PHASE MATRIX

Phase Matrix, Inc.
Customer Support
109 Bonaventura Drive
San Jose, CA 95134

Tel: +1 (408) 428-1000
Toll free: +1 (877) 474-2736
Fax: +1 (408) 428-1500
Email: service@phasematrix.com
Web: www.phasematrix.com



SAFETY

The Phase Matrix 1313B is designed and tested according to international safety requirements, but as with all electronic equipment, certain precautions must be observed. This manual contains information, cautions, and warnings that must be followed to prevent the possibility of personal injury and/or damage to the instrument.

SAFETY AND HAZARD SYMBOLS

WARNING

A WARNING denotes a hazard to personnel. It calls attention to a procedure or practice, which, if not correctly performed or adhered to, could result in personal injury.

CAUTION

A CAUTION denotes a hazard to the equipment. It calls attention to an operating procedure or practice, which, if not correctly performed or adhered to, could result in damage to or destruction of part or all of the product.



This is a general warning that appears whenever care is necessary to prevent damage to the equipment.



Dangerous Voltage



Toxic Substance



Static-Sensitive Component



Fire Hazard

OVERALL SAFETY CONSIDERATIONS



WARNING

Before this instrument is powered on, its protective earth terminals *must* be in contact with the mainframe's protective conductor. The mainframe *must* be connected to a power source that has a protective earth contact. The protective action must not be negated by using an extension cord (power cable) or adapter that does not have a protective earth (grounding) conductor.

WARNING



Whenever it is likely that electrical protection is impaired, the instrument *must* be made inoperative and be secured against any unintended operation.

WARNING



All protective earth terminals, extension cords, autotransformers, and other devices connected to this instrument *must* be connected to a socket/outlet that has a protective earth contact. Any interruption of the protection causes a potential shock hazard that can result in personal injury.

WARNING



The power supply is energized whenever power is connected to this instrument. Internal adjustments or servicing that must be done with the power connected must be performed only by qualified personnel.

WARNING



Some of the components used in this instrument contain resins and other chemicals that give off toxic fumes if burned. Be sure to dispose of these items properly.

CAUTION



Some static-sensitive components are used in this instrument. These components can be damaged if handled incorrectly.



This Page Intentionally Left Blank

TABLE OF CONTENTS

WARRANTY. iii
CERTIFICATION iii
MANUAL CHANGE INFORMATION iii
CONTACTING PHASE MATRIX iii
SAFETY. iv
SAFETY AND HAZARD SYMBOLS iv
OVERALL SAFETY CONSIDERATIONS v

SECTION 1: GENERAL INFORMATION

INTRODUCTION	1-1
OPERATING CONDITIONS	1-1
STORAGE	1-2
SPECIFICATIONS.	1-2
INPUT	1-2
OUTPUT	1-3
SWITCHING/SETTLING TIMES.	1-4
LOCAL OSCILLATOR	1-4
OPTIONS.	1-4
POWER METER OPTION	1-5
GENERAL/MECHANICAL	1-5
VXIbus	1-6
ACCESSORIES.	1-6

SECTION 2: INSTALLATION

UNPACKING	2-1
SETTING THE LOGICAL ADDRESS	2-1
POWER AND COOLING	2-2
INSTALLATION	2-2
INCOMING OPERATIONAL CHECK.	2-4
IF A PROBLEM OCCURS.	2-4
SERVICE INFORMATION	2-4
PERIODIC MAINTENANCE	2-4
DOWNCONVERTER IDENTIFICATION.	2-4
FACTORY SERVICE	2-5
SHIPPING INSTRUCTIONS	2-5



**SECTION 3:
CONNECTORS AND INDICATORS**

INTRODUCTION 3-1
FRONT PANEL STATUS LEDs 3-2
FRONT PANEL CONNECTORS 3-2
 MEASUREMENT CHANNEL OUTPUT CONNECTORS 3-2
 MEASUREMENT CHANNEL INPUT CONNECTORS. 3-3

**SECTION 4:
THEORY OF OPERATION**

INTRODUCTION 4-1
SYSTEM OVERVIEW 4-2
THE INPUT SECTION 4-2
 BYPASS SIGNAL PATH 4-2
 LOW BAND SIGNAL PATH 4-3
 HIGH BAND SIGNAL PATH. 4-4
THE OUTPUT SECTION. 4-5
 PRIMARY OUTPUT PATH. 4-5
 AUXILIARY OUTPUT PATH 4-6
DETAILED CIRCUIT DESCRIPTIONS 4-6
 THE BYPASS PATH. 4-7
 THE LOW BAND PATH 4-8
 THE HIGH BAND PATH. 4-10
 THE OUTPUT SECTION. 4-11
 THE VIDEO DETECTOR. 4-12
 AUXILIARY IF OUTPUT 4-13
VXIbus INTERFACE AND CONTROL 4-14
INITIALIZATION AND RESETS. 4-15

**SECTION 5:
DRIVER PROGRAMMING**

INTRODUCTION 5-1
REQUIREMENTS 5-2
ERROR AND STATUS INFORMATION 5-3
FUNCTIONS 5-4
 PM1313B_CLOSE 5-4
 PM1313B_ERRORMESSAGE 5-5
 PM1313B_GET_STATUS 5-6

PM1313B_INIT	5-8
PM1313B_PWR_CAL	5-12
PM1313B_PWR_CAL_ALL	5-14
PM1313B_PWR_CLS	5-16
PM1313B_PWR_DBM	5-18
PM1313B_PWR_DIAG	5-20
PM1313B_PWR_DIAGDPRFILL	5-24
PM1313B_PWR_DIAGDPRTEST	5-26
PM1313B_PWR_INIT	5-28
PM1313B_PWR_MSG_RECEIVE	5-30
PM1313B_PWR_MSGPROC	5-32
PM1313B_PWR_MSGSEND	5-34
PM1313B_PWR_OFF	5-36
PM1313B_PWR_POST	5-38
PM1313B_PWR_PRESET	5-40
PM1313B_PWR_RANGE	5-42
PM1313B_PWR_REFOSC_OFF	5-44
PM1313B_PWR_REFOSC_ON	5-46
PM1313B_PWR_RESET	5-48
PM1313B_PWR_SELF_TEST	5-50
PM1313B_PWR_STATUS_AND_ERRORS	5-52
PM1313B_PWR_TASK1	5-54
PM1313B_PWR_TRIGGER_CONT	5-57
PM1313B_PWR_TRIGGER_HOLD	5-59
PM1313B_PWR_TRIGGER_IMM	5-61
PM1313B_PWR_WATT	5-63
PM1313B_PWR_ZERO	5-65
PM1313B_REGISTER_STATUS	5-67
PM1313B_RESET	5-69
PM1313B_SET_BYPASS_AMP_STATE	5-70
PM1313B_SET_DETECTOR_TIME	5-71
PM1313B_SET_FILTER	5-72
PM1313B_SET_Highband_PREAMP_STATE	5-74
PM1313B_SET_IF_GAIN_1	5-75
PM1313B_SET_IF_GAIN_2	5-76
PM1313B_SET_IF_OUTPUT_PATH	5-77
PM1313B_SET_IF_SIGNAL_PATH	5-78
PM1313B_SET_LOWBAND_SIGNAL_PATH	5-80
PM1313B_SET_RF_SIGNAL_PATH	5-82



PM1313B_SET_STEP_ATTENUATOR 5-83
 PM1313B_SET_WIDEBAND_STATE 5-85
 PM1313B_SET_YIG_FREQUENCY. 5-86
 PM1313B_SET_YIG_STATE 5-87
 PM1313B_UPDATE_REGISTER_VALUE 5-88

**SECTION 6:
 DIRECT REGISTER PROGRAMMING**

INTRODUCTION 6-1
 BASIC CONFIGURATION REGISTERS. 6-1
 A16 REGISTERS 08_{HEX} - 3F_{HEX} NOT USED 6-4
 A24 REGISTERS 6-4
 IF FILTER FREQUENCY PLAN 6-11
 LOCAL OSCILLATOR FREQUENCY PLAN 6-11

**SECTION 7:
 CALIBRATION**

INTRODUCTION 7-1
 CALIBRATION FILES. 7-1
 EQUIPMENT REQUIRED. 7-1
 IF GAIN CALIBRATION 7-2
 CALIBRATION PROCEDURE 7-2
 ATTENUATOR CALIBRATION. 7-3
 CALIBRATION PROCEDURE 7-4
 YIG FILTER CALIBRATION 7-4
 FREQUENCY CALIBRATION PROCEDURE. 7-5
 AMPLITUDE CALIBRATION PROCEDURE 7-6
 AUXILIARY IF CALIBRATION PROCEDURE 7-7

**APPENDIX A:
 VXIbus**

INTRODUCTION A-1
 VMEbus BACKGROUND A-1
 THE VXIbus EXTENSIONS A-2
 VXIbus MODULES. A-2
 VXIbus SUBSYSTEMS. A-3
 P2 CONNECTOR DEFINITION A-3
 P3 CONNECTOR DEFINITION A-3
 VXIbus SYSTEM ARCHITECTURE A-3

**APPENDIX B:
FUNCTIONAL BLOCK DIAGRAMS**

FUNCTIONAL BLOCK DIAGRAMSB-1



This Page Intentionally Left Blank

1

GENERAL INFORMATION

INTRODUCTION

The Phase Matrix Model 1313B VXI-Bus Downconverter is a register-based VXI module capable of downconverting microwave signals to a frequency usable by an analog-to-digital converter for additional digital processing and display. The 1313B has a guaranteed frequency range of 1 MHz to 26.5 GHz, although it is generally usable at frequencies as low as 100 KHz. Its dynamic range is dependent upon frequency and bandwidth. The maximum input signal level is 1 watt. Other than interface address switches, the instrument has no manual controls. It is normally controlled via a computer utilizing a simple register based system. The 1313B is a VXIbus, C-size, plug-in module that requires a VXIbus mainframe for operation.

OPERATING CONDITIONS

The Phase Matrix 1313B downconverter is designed to operate at temperatures from 0° C to 50° C at a relative humidity not exceeding 95% (75% over 25° C; 45% over 40° C). The downconverter performs to specifications at altitudes not exceeding 10,000 ft. (3050 m). It is fungus resistant. The module housings are not designed to provide protection from severe mechanical shock or liquids and are intended for normal VXIbus use in an environmentally clean area.

The 1313B downconverter meets the requirements of MIL-T-28800D, Type III, Class 7, Style G, Color R with the following modifications and exceptions:

1. The non-operating temperature requirement is limited to the range of -40° C to +70° C.
2. The operating and non-operating altitude requirements are not invoked.
3. The EMI requirement is modified as follows:
 - a. For frequencies ≥ 1 GHz, RE02 of MIL-STD-461C applies.
 - b. For frequencies < 1 GHz, VXI-bus System Specifications Revision 1.3/1.4 applies.
4. The warm up time is 15 minutes at 25° C ambient temperature.



STORAGE

To prevent damage to the downconverter, it must be stored in an antistatic bag or enclosure and in an environment that is protected from moisture, dust, and other contaminants. Do not expose the instrument to temperatures below -40°C or above $+70^{\circ}\text{C}$, altitudes above 40,000 ft. (12000 m), nor vibration exceeding 2 g.

SPECIFICATIONS

		INPUT
RF input frequency range	1 MHz to 26.5 GHz (with Option 01) (Useable to 100 kHz)	
RF input compression point (at 0 dB attenuation)	-30 dBm min.	
RF input level (continuous, without damage)	+30 dBm min. (at 10 dB attenuation)	
RF input return loss (50 Ω)	0.1 to 1 MHz < -10 dB 1 MHz to 12 GHz < -14 dB 12.5 GHz to 18 GHz < -10 dB 18 GHz to 26.5 GHz < -8 dB	
Noise		
No preselection	<8.5 GHz (20 dB max.) <26.5 GHz (30 dB max.)	
Preselection	<8.5 GHz (28 dB max.) <26.5 GHz (38 dB max.)	
RF input IP3 (at 0 dB attenuation)	-10 dBm min. (10 MHz spacing) (Tested with spurious tones in band and intermodulation products out of band.)	
Spurious single-tone signals at input (LO leakage at Input)	-90 dBm max. (preselection) -50 dBm max. (no preselection)	
Input step attenuator	0 to 70 dB in 10 dB steps	

INPUT (Continued)

Suggested step-attenuator settings for linear operation *

<u>RF Input</u>	<u>Input Step Attenuator Setting</u>
+30 dBm	70 dB
+20 dBm	60 dB
+10 dBm	50 dB
0 dBm	40 dB
-10 dBm	30 dB
-20 dBm	20 dB
-30 dBm	10 dB
-40 dBm	0 dB

* The Downconverter can be operated at higher input levels by adjusting the IF attenuation accordingly. However, the -2 dBm (500 mVp-p) IF output must always be maintained for linear response.

OUTPUT

RF to IF gain (0 dB attenuation)	40 dB typ.
IF output levels (0 dB step attenuation)	
<u>RF Input</u>	<u>IF Output (50 Ω)</u>
-40 dBm	-2 dBm (500 mVp-p)
-60 dBm	-22 dBm (50 mVp-p)
-80 dBm	-42 dBm (5 mVp-p)
-100 dBm	-62 dBm (0.5 mVp-p)
Output IF center frequency	250 MHz (settable via LO1)
Output IF frequency bandwidth	350 MHz min. (1 dB bandwidth)
Output IF level variation	± 1 dB max.
Output IF second harmonic distortion	Main IF (250 MHz) > 60 dB Aux. IF (21.4 MHz) > 80 dB
Output level variation (any 50 MHz IF segment)	0.7 dB
LO leakage at main IF (250 MHz)	+10 dBc max. (RF in < 80 MHz)
IF gain control	63 dB in 0.5 dB steps
Spurious single-tone signals at IF	-80 dBm max. (residual spurs, input terminated, measured with SA at RF inputs > 150 MHz)



SWITCHING/SETTLING TIMES

(The maximum time interval from the time a command is written to the appropriate register until the unit has switched and settled at the newly commanded mode of operation.)

Input Step Attenuator	25 ms
IF Attenuator	5 μs
YIG Preselector enabled/disabled (Option 02)	20 ms
Low-band through path/converted path (Option 01)	5 ms
Low Band/High Band (Option 01)	20 ms
Wide BandIF/Narrow Band IF (Option 03)	5 ms

LOCAL OSCILLATOR

Ext LO1	3–9 GHz, +10 dBm nom. in 1 Hz steps
Ext LO2	3.25 GHz fixed, 0 dBm nom.
Ext LO3 (Option 03)	228 MHz fixed, 0 dBm nom.

OPTIONS

OPT-01: Low-band frequency range *	1 MHz to 2.9 GHz (Useable to 100 kHz)
Low-band input bandwidth (instantaneous)	40 MHz (1 dB) min.
OPT-02: YIG Preselector freq. range *	2.7 GHz to 26.5 GHz
3 dB Bandwidth	40 MHz min., 120 MHz max.
Topology	4 pole, nominal 24 dB/oct
Tuning speed	<5 ms @ 50 MHz step
Tuning accuracy	±35 MHz uncorrected
OPT-03: Auxilliary IF output *	
Center frequency	21.4 MHz
Aux. IF frequency BW (0.5 dB)	50 kHz / 500 kHz / 2 MHz / 8 MHz (user selectable)
Aux. IF level	Same as main IF
Aux. IF filter – filter level variation	0.7 dB max.
OPT-04: Video detected output *	
Input frequency bandwidth	50 MHz min.
Output bandwidth (no preselection)	10 nSec. risetime min. at >250 MHz IF input to detector
Output IF level	Det. Sens. to 0 dBm
D/C output level @ –2 dBm IF out	1 V min. polarity positive
D/C output level error over temperature	1 dB max. (0° C to +55° C)
OPT-10: Power Meter	

* OPT-01, OPT-02, OPT-03, and OPT-04 are included in the –D6 version.

POWER METER OPTION

The power-meter option (OPT-10) adds National Institute of Standards and Technology (NIST) traceable power-measurement capability to the Downconverter module. This option contains all the necessary interfaces as well as reference standard for interfacing to the Agilent* 8480 series of power sensors. The power and frequency ranges of the power-measurement option are dependent on the power-sensor model used.

Frequency range	100 kHz to 50 GHz, sensor-dependent (see Agilent sensor specifications)
Power range	-70 to +44 dBm
Power sensors supported	Agilent Models 8487A, 8485A, 8482A, 8481D, 8481A, 8481B, 8482B, 8481H, 8482H, 8485D, 8487D
Resolution	0.01 dB in log mode, 0.1% of full scale in linear mode
Data units	
Absolute	dBm or Watts
Relative	db or %
Accuracy	± 0.02 dB or $\pm 0.5\%$. Add power-sensor linearity specification to overall system accuracy.
Instrumentation	
Zero Set	Sensor-dependent (see Agilent sensor specifications)
Power reference output	1.00 mW, factory set to $\pm 0.7\%$, traceable to NIST
Power reference accuracy	$\pm 1.2\%$ worst case ($\pm 0.9\%$ RSS) for one year
Power reference frequency	50 MHz nom.
Connector	N-Type female

* Agilent is a trademark of Agilent Corporation.

GENERAL/MECHANICAL

Operating temperature range	0° C to +55° C
Non-operating temperature	-40° C to +70° C
Humidity	0% to 90%, Non-Condensing
Operating altitude	10,000 ft.
Non-operating altitude	15,000 ft.
Vibration	Per MIL-PRF-28800 Class 1 enclosure, 5 to 55 Hz at 0.7 to 3 g
Safety	Designed for conformance with IEC-1010
EMI	
Below 1 GHz	Complies with VXIbus Revision 1.3/1.4 specifications
Above 1 GHz	Complies with RE02 of MIL-STD-461C



GENERAL/MECHANICAL (Continued)

Connectors

RF Input	Precision APC-3.5 mm female (SMA-compatible)
LO 1 Input, LO 2 Input, LO 3 Input, Aux, Main IF Output, Aux IF Output	} SMA female (50 Ω nom.)

Size	VXI C-size, one slot
Weight	6 lbs. max. (all options installed)
Mechanical	Complies with VXIbus Revision 2.0 specifications

VXIbus

Module size	C-Size, one slot
Device type	Register-Based (A16/A24)
Protocol	Not Used
Local bus	Not Used
ECLTRG utilization	Not Used
TTLTRG utilization	Not Used
CLK10 utilization	Not Used
Cooling	1 mm H ₂ O @ 5 liters/second for 15° C internal temperature rise
Warm-up time	15 minutes max. @ +25° C ambient temperature
Power dissipation	40 W typ. (all options installed), 60 W max.

Voltage	+5 V	+12 V	+24 V	-2 V	-5.2 V	-12 V	-24 V
DC Current	0.8 A	1.5 A	0.5 A	N/A	0.25 A	N/A	1.2 A

ACCESSORIES

Phase Matrix 20309 or 20309-D7	Synthesized Microwave Local Oscillator
Phase Matrix 1140B	Synthesized Signal Source
M20309-ACC001	Cable Assy, Coax, SMA, LO1A
M20309-ACC002	Cable Assy, Coax, SMA, LO2A
M20309-ACC003	Cable Assy, Coax, SMA, LO3A
M20309-ACC004	Cable Assy, Coax, SMA, Generic, LO1, LO2, LO3
M20309-ACC005	Cable Assy, Coax, SMA, LO1B *
M20309-ACC006	Cable Assy, Coax, SMA, LO2B *
M20309-ACC007	Cable Assy, Coax, SMA, LO3B *

* Used to connect a second 1313B to a 20309-D7.

2

INSTALLATION

UNPACKING

The Phase Matrix 1313B VXI-Bus Downconverter arrives ready for operation. Carefully inspect the shipping carton for any sign of damage. If the carton is damaged, immediately notify the shipper's agent.

Remove the packing carton and supports, being careful not to mar or damage the instrument. Make a complete visual inspection of the module, checking for any damage or missing components. Check that all switches and controls operate mechanically. Report any damage to Phase Matrix immediately.

SETTING THE LOGICAL ADDRESS

Before installing the downconverter in the VXIbus mainframe, verify that the logical address is between 1 and 254 (decimal). The factory default setting for the logical address of the downconverter is 14 hexadecimal (20 decimal). The logical address of the downconverter is set using the two rotary-type hexadecimal switches located on the bottom of the module (see Figure 2-1 on page 2-2). To set the logical address, set each switch to the hexadecimal value desired. For example, to set a logical address of 17 hexadecimal (23 decimal), use a small flathead screwdriver (or similar tool), and rotate the MSB switch to 1 and the LSB switch to 7. The logical address desired must be a value between decimal 1 and 254. Logical address 0 is reserved for Slot 0 devices. Logical address 255 is reserved for dynamically configured devices. The Phase Matrix 1313B does not support dynamic configuration.

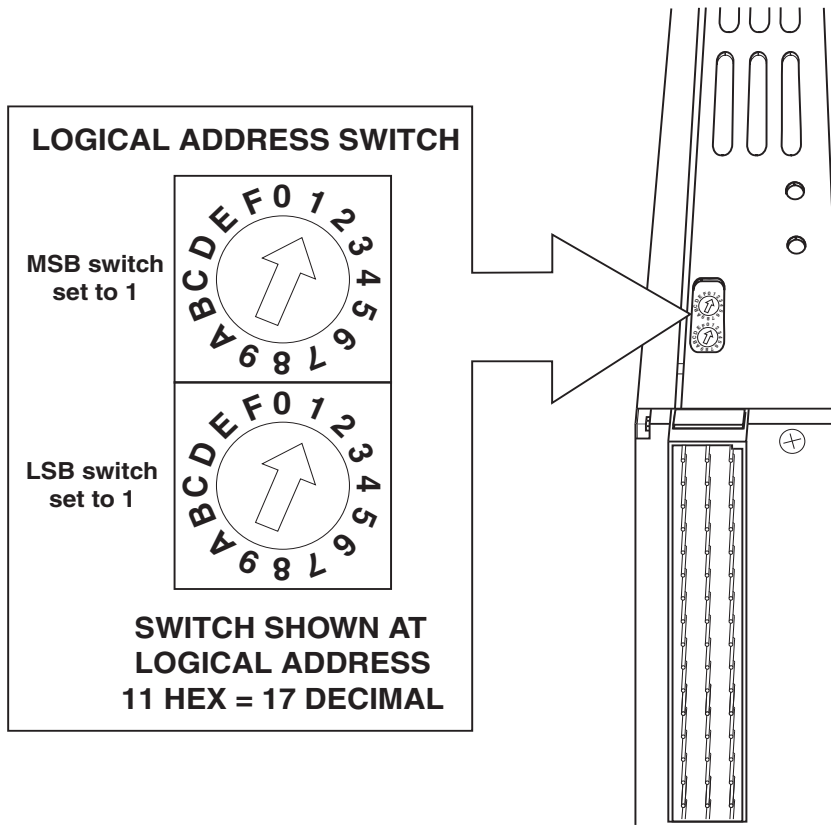

Figure 2-1. Logical Address Switches

POWER AND COOLING

The Phase Matrix 1313B downconverter operates over an ambient temperature range from 0° C to 50° C and can consume up to 55 watts (see “Specifications” in Section 1). When configuring your VXIbus system, make sure that the chassis has sufficient power and cooling capacity for the downconverter. Refer to chassis specifications and cooling-capacity curves.

INSTALLATION

The 1313B is a VXIbus module designed to be installed in a VXIbus mainframe. Prior to installing the downconverter in a VXIbus mainframe, verify that all VXI defined voltages are present and within limits, and make sure the mainframe is capable of supplying the required current (see “Specifications” in Section 1).

CAUTION



Never insert the downconverter into a VXIbus mainframe with power applied. Doing so will damage the downconverter.

CAUTION



Verify that all VXI-defined voltages are present and within specification and that the mainframe is capable of supplying the required current before inserting a downconverter in a VXI-bus mainframe.

CAUTION



All unused slots of VXIbus mainframes must have blank panels installed to ensure proper airflow through the installed modules.

NOTE



The 1313B Downconverter must be installed in the VXI chassis immediately to the left of the 20309 Local Oscillator (see Figure 2-2). If it is installed in any other position, the semi-rigid cables supplied with the 1313B will not fit.

The downconverter is a 3-slot, C-size module that can be installed into any slot of a VXIbus mainframe except slot 0, as slot 0 is reserved for the resource manager. Use the following procedure to install the downconverter into the VXIbus mainframe:

1. Turn the mainframe power OFF.
2. Position the downconverter so that its card edges are in the front ends of the mainframe guides (top and bottom).
3. Gently slide the downconverter into the mainframe until you feel resistance as the connectors at the rear of the downconverter begin to mate with the backplane connectors.
4. Firmly seat the downconverter module in the mainframe, making sure that the front panel is flush with the front surface of the mainframe.

CAUTION



Never use the module retaining screws to seat the downconverter in the mainframe. Doing so may damage the module and/or the mainframe chassis.

5. Tighten the retaining screws to ensure the module remains fully seated.



INCOMING OPERATIONAL CHECK

A VXIbus mainframe, a slot-0 resource manager, and an instrument controller are required to verify that the downconverter is operational. With the downconverter installed in a VXIbus mainframe, two types of tests can be performed to verify proper operation.

1. Observe the state of the **Failed** LED. Whenever a VXIbus mainframe is energized, the resource manager queries each device checking for proper operation. The downconverter also performs a power-on self-test. The **Failed** LED lights during the self test or if any problems are detected.
2. Query the instrument regarding its operational status by using a controller to issue the self-test query, ***TST?**. The instrument returns a 0 if all tests pass.

IF A PROBLEM OCCURS

If a problem does occur, make the following checks before returning the instrument for repair:

1. Verify the logical address setting on the instrument.
2. Verify that all specified VXI voltages are present.
3. Determine whether the VXIbus AC fail line is asserted. The downconverter monitors this line, and if the line is asserted, the downconverter does not function.
4. If the module has never worked in the particular system, the problem may be in the system rather than in the instrument. If this occurs, contact Phase Matrix Customer Support.

SERVICE INFORMATION

PERIODIC MAINTENANCE

No periodic preventive maintenance is required. However, to maintain accuracy, Phase Matrix recommends that you recalibrate the downconverter every 12 months or whenever a problem is suspected (see Section 7, “Calibration”). The specific calibration interval depends upon the accuracy required.

DOWNCONVERTER IDENTIFICATION

The downconverter is identified by three sets of numbers: the model number (PM 1313B), a serial number, and a configuration-control number (CCN). These numbers, which must be included in any correspondence regarding your downconverter, are on a label on the top of the module.

FACTORY SERVICE

If you are returning the downconverter to Phase Matrix for service or repair, be sure to include the following information with the shipment:

- Name and address of owner
- Model, complete serial number, and CCN of the downconverter
- A complete description of the problem. Be sure to provide enough information so that the problem can be verified:
 - Under what conditions did the problem occur?
 - Did the unit work and then fail?
 - What other equipment was connected to the downconverter when the problem occurred?
- The name and telephone number of someone familiar with the problem who can be contacted by Phase Matrix if any further information is required
- The shipping address to which the downconverter is to be returned. Include any special shipping instructions.

SHIPPING INSTRUCTIONS

Place the downconverter in an antistatic bag or enclosure, wrap it in heavy plastic or kraft paper, and repack it in the original container, if available. If the original container cannot be used, pack in a heavy (275 pound test) double-walled carton with approximately four inches of packing material between the downconverter and the inner carton. Seal the carton with strong filament tape or strapping. Mark the carton to indicate that it contains a fragile electronic instrument. Ship the package to Phase Matrix at the following address:

Phase Matrix, Inc.
109 E. Bonaventura Dr.
San Jose, CA 95134

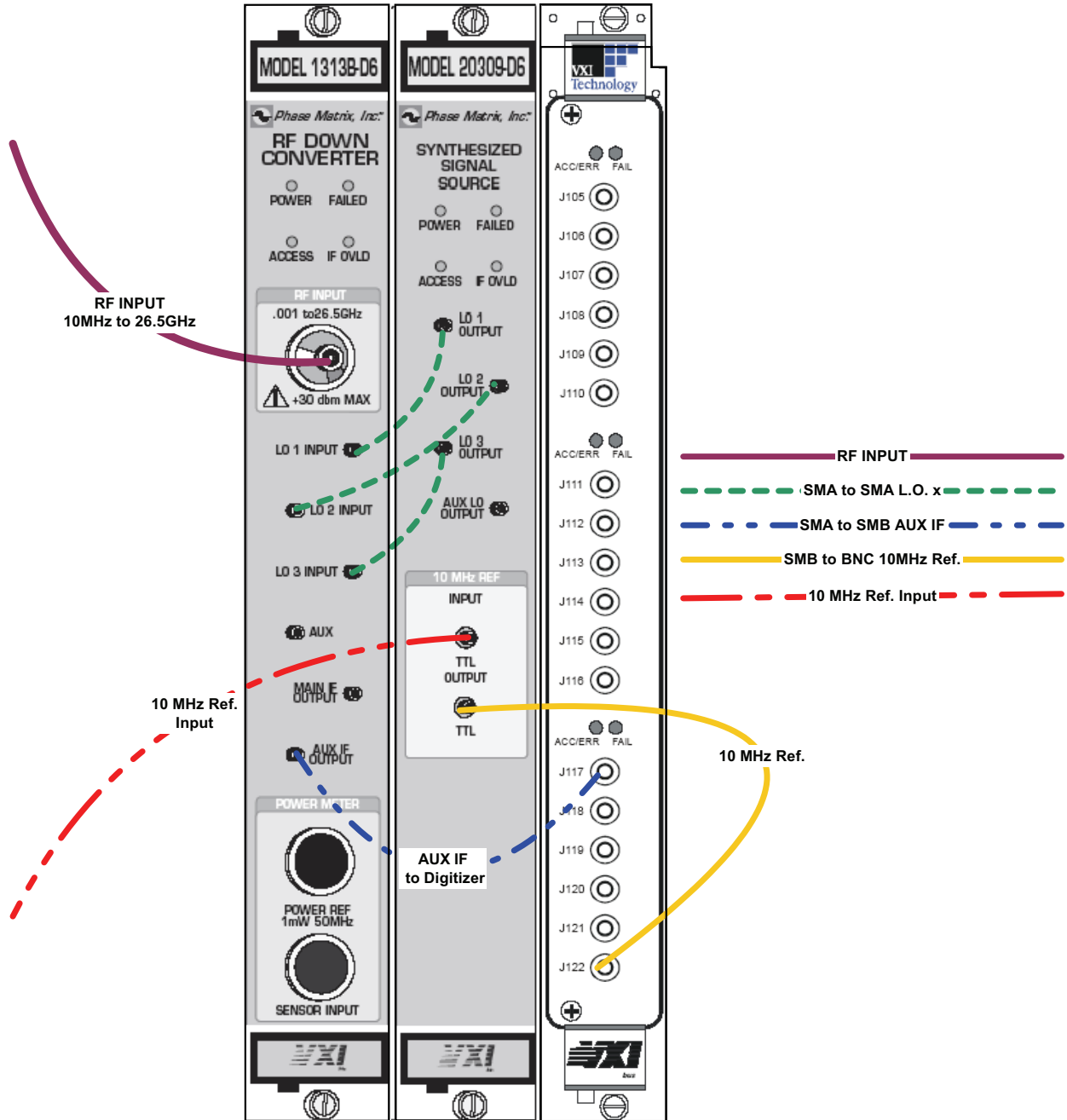

Figure 2-2. Installation Example: 1313B Downconverter, 20309 Synthesizer, and VXITech 2601 Digitizer

3

CONNECTORS AND INDICATORS

INTRODUCTION

This section describes the functions of the front-panel LEDs and connectors. The front panel of the 1313B is shown in Figure 3-1.

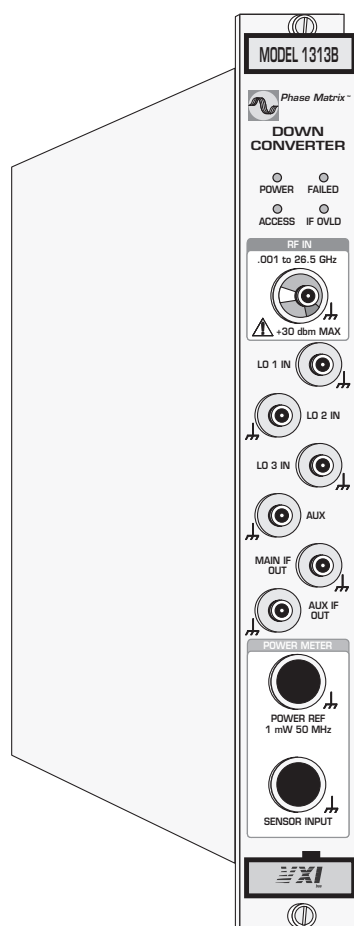

Figure 3-1. 1313B Downconverter



FRONT PANEL STATUS LEDs

- **POWER LED:** This LED lights whenever all required power is being supplied to the Downconverter. The Downconverter senses the voltage on all lines that are used and checks for sufficient voltage. If the required voltages are not present, the LED does not light.
- **FAILED LED:** This LED lights if the Downconverter has failed. Failures typically result from internal component failure or inadequate power-supply current. The **FAILED** LED follows the condition of the VXIbus **SYSFAIL** line. If the unit fails, the LED remains lit, even if **SYSFAIL** is inhibited by the commander.
- **ACCESS LED:** This LED lights when a commander is accessing the Downconverter's VXIbus registers.
- **IF OVLD LED:** This LED lights to indicate that the input signal level at the **CH 1 RF INPUT** is too high, the input step attenuator is not set properly, or the IF step attenuator is not set properly. When the **IF OVLD** LED is lit, the downconverter may function, but it will fail to meet the specifications.

FRONT PANEL CONNECTORS

The 1313B RF Downconverter has three output connectors and four input connectors. The 1313B does not use the **POWER METER** connectors.

MEASUREMENT CHANNEL OUTPUT CONNECTORS

AUX

The **AUX** output connector is used to route the detected video signal to the front panel. This output can be used in conjunction with the **MAIN IF OUTPUT**. It is an SMA female connector with a nominal 50-ohm impedance.

MAIN IF OUTPUT

The **MAIN IF OUTPUT** connector is the Downconverter's main (wideband) IF output. This output's center frequency is 250 MHz with a minimum bandwidth of 350 MHz. It is used to drive a digitizer directly. It is an SMA female connector with a nominal 50-ohm impedance.

AUX IF OUTPUT

The **AUX IF OUTPUT** connector is the alternate (narrowband) IF output of the Downconverter. The center frequency is fixed at 21.4 MHz. The bandwidth of this IF output is user-configurable (50 kHz, 500 kHz, 2 MHz, or 8 MHz). It is an SMA female connector with a nominal 50-ohm impedance.

MEASUREMENT CHANNEL INPUT CONNECTORS

RF INPUT

This is the Downconverter's main input. It is a precision APC-3.5 mm female (SMA-compatible) connector with a nominal 50-ohm impedance.

LO1 INPUT

This is the main local-oscillator input that is required by the microwave band and the low-band option. The frequency range is from 3.0 to 9.0 GHz with a minimum level of +10 dBm. It is an SMA female connector with a nominal 50-ohm impedance.

LO2 INPUT

This is a 3.25 GHz local-oscillator input that is required by the low-band option. The frequency is fixed with a minimum level of +10 dBm. It is an SMA female connector with a nominal 50-ohm impedance.

LO3 INPUT

This is a 228 MHz local-oscillator input that is required for the double-down-conversion **AUX IF OUTPUT** option. The frequency is fixed with a minimum level of 0 dBm. It is an SMA female connector with a nominal 50-ohm impedance.



This Page Intentionally Left Blank

4

THEORY OF OPERATION

INTRODUCTION

The Phase Matrix 1313B Downconverter is designed as a highly versatile basic building block for use in a VXIbus automated test system (ATS). The 1313B is a special model in the Phase Matrix 1313B family of downconverters, which convert frequencies in the range of 1 MHz to 26.5 GHz to RF outputs of 250 MHz (nominal) and 21.4 MHz and a video output. Three externally supplied local oscillator (LO) inputs are required: A First LO of 3 – 9 GHz, a Second LO of 3.25 GHz (nominal), and a Third LO of 228 MHz. These external LO signals may be supplied by a Phase Matrix 20309 VXIbus Local Oscillator or other suitable signal sources.

Note that, while the filters in the 1313B limit its bandwidth, it contains no frequency determining circuitry. Frequencies are set totally by the externally supplied local oscillator signals. Specified performance is based upon using the frequencies delineated in this manual and in the specification of the 1313B. Phase Matrix, Inc. makes no representation of the performance of the device when used under other conditions, i.e., with different LO frequencies to produce different output IF frequencies. However, the following discussion outlines the mathematics of the downconverter so that the customer can define the LO frequencies necessary to operate the 1313B at other output IF frequencies. Should the customer choose to operate the 1313B outside the specification, it is highly recommended that the necessary testing be done to ensure that the bandwidth of the unit is sufficient to function satisfactorily under the proposed operating conditions.

The 1313B is a highly versatile device with many applications. And, while the same considerations apply to any application, this discussion assumes the output of the downconverter is applied to the input of a digitizer, and the digitized IF output is then digitally processed to produce a spectrum-analyzer display or some similar application.

The 1313B is a register-controlled instrument. To control the instrument, the user writes the proper control word to the proper register, and the internal logic circuitry does the necessary decoding to set the internal switches so as to execute the command. One does not need to understand the architecture of the 1313B logic circuitry to program and operate it.



SYSTEM OVERVIEW

This section provides a simplified overview of the 1313B circuitry followed by detailed circuit descriptions. In this overview, the unit's RF circuitry is divided into two sections: an input section and an output section. This division is for purposes of illustration only and does not represent physical sub-assemblies within the unit. While this discussion delineates the functioning of the various options, the accompanying illustrations assume that all options are installed.

THE INPUT SECTION

The 1313B Input Section has three basic signal paths. The first of these, the Bypass Path, is illustrated in Figure 4-1.

NOTE

Note that the reference designators of the filters and mixers in the simplified block diagrams in Figure 4-1 through Figure 4-5 apply only to this discussion and do not refer to the actual reference designators in the 1313B. The filters and mixers shown may actually consist of multiple filters and other components. Furthermore, gain and most attenuation stages are not shown. More detailed block diagrams are contained in Appendix B.

BYPASS SIGNAL PATH

In the Bypass Signal Path (Figure 4-1), all frequency conversion stages are bypassed, and the input signal is simply passed through to the output. The Bypass Signal Path is specified for use over a range of 1 MHz to 100 MHz. On the low frequency end of the band, it is generally usable to well below 100 KHz. There is no filtering in the signal path, and the upper frequency limit is constrained only by the response of the amplifiers. This signal path is, in general, usable up to the maximum frequency of the digitizer attached to the output. Amplification (not shown) is provided such that the path gain is equal to the gain of the other signal paths (38 dB, nominal). For reasons that are discussed later, the Bypass Signal Path cannot be used with the Alternate IF Output (IF2).

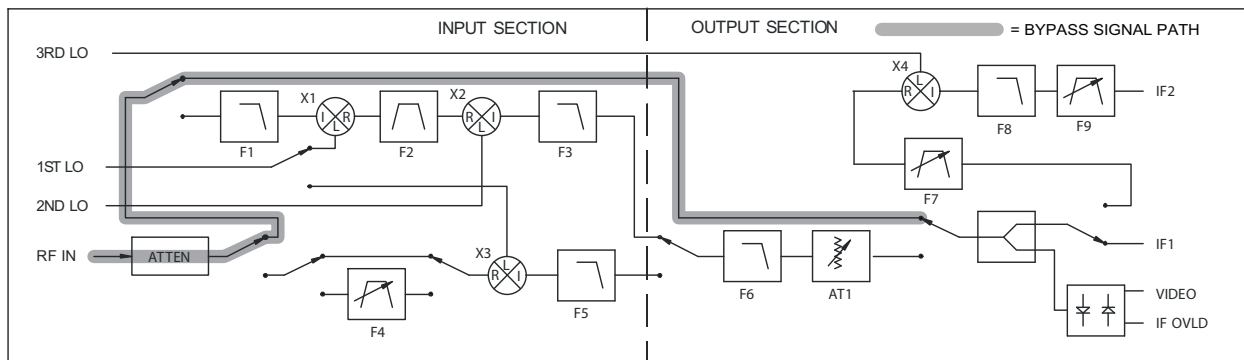

Figure 4-1. Bypass Signal Path

LOW BAND SIGNAL PATH

The Low Band Signal Path (Figure 4-2) is specified for signals in the range of 100 MHz to 2.9 GHz. In mixer X1, the input signal is mixed with a First LO signal of 3.6 GHz to 6.4 GHz to produce an intermediate frequency (IF) difference signal of 3.5 GHz. This signal is filtered by an IF strip consisting of a series of bandpass filters, amplifiers, and attenuators (represented by F2 in Figure 4-2). The IF strip sets the bandwidth of the path at a nominal 40 MHz (1 dB bandwidth). Input filter F1 is a series of buffered low-pass filters which perform the functions of image rejection and attenuation of the LO1 signal appearing at the RF input.

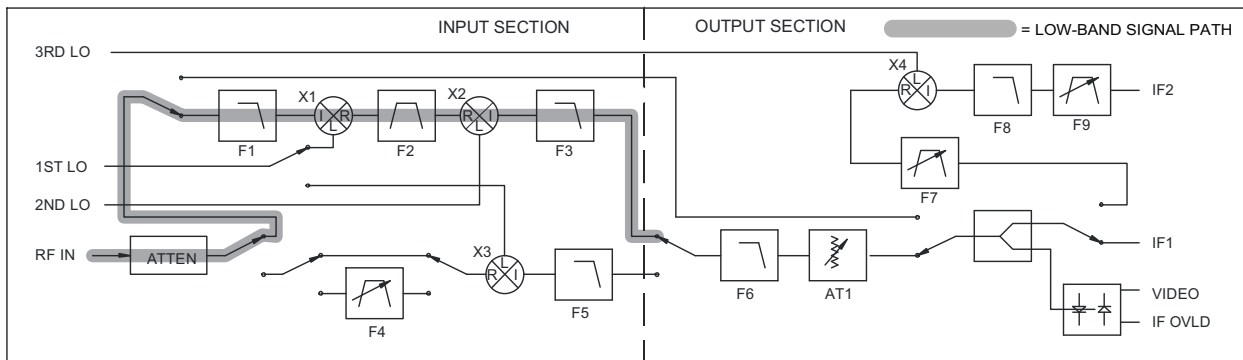

Figure 4-2. Low Band Signal Path

The 3.5 GHz IF signal is downconverted to 250 MHz by subtracting a 3.25 GHz Second LO signal in mixer X2. A buffered low-pass filter, F3, terminates the mixer and suppresses higher frequency mixer products.

A Second LO frequency of other than 3.25 GHz can be used to produce a different output frequency. The maximum output frequency is limited by the response of F6 in the output section of the 1313B. Phase Matrix does not warrant the specifications of the unit under any conditions other than the use of a 3.6 GHz to 6.4 GHz First LO and a 3.25 GHz Second LO to produce a 250 MHz output from a 100 MHz to 2.9 GHz input. To operate the unit at other than the specified output frequency or outside the specified band, Phase Matrix recommends that adequate testing be done to assure satisfactory operation under the proposed conditions of operation. It must be noted that, when a 3.25 MHz Second LO is used, the output frequency is inverted; i.e., an increase in input frequency results in a decrease in output frequency.



HIGH BAND SIGNAL PATH

The High Band Signal Path (Figure 4-3) is intended for use at frequencies from 2.9 GHz to 26.5 GHz. Mixer X3 is a Fundamental/Third Harmonic mixer which produces an output equal to the difference between the input signal and the First LO or the input signal and the third harmonic of the First LO. The difference frequency is nominally 250 MHz, the frequency at which Phase Matrix warrants the device specifications. To use a different LO frequency to operate the unit at a different difference (output) frequency, adequate testing should be performed to verify satisfactory performance.

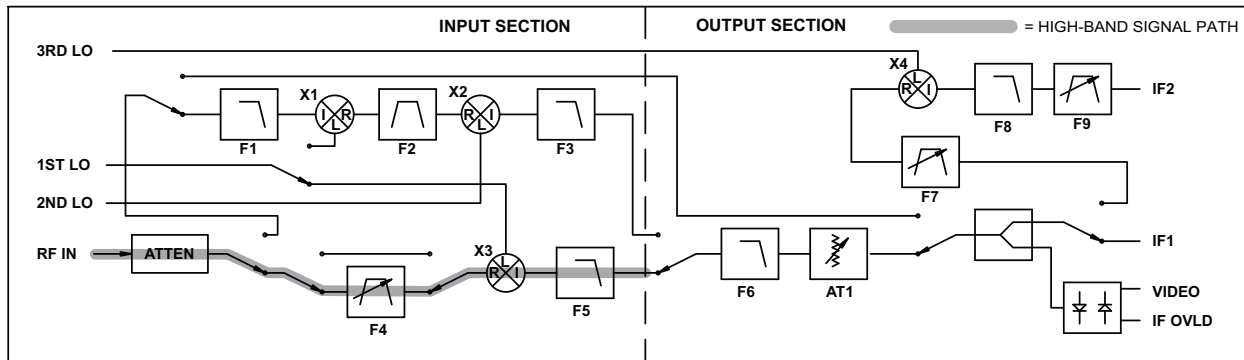

Figure 4-3. High Band Signal Path

Although high-side LO injection is probably utilized in most applications, low-side injection can also be used.

NOTE

When high-side injection is chosen, the user must be aware that the resulting output signal is inverted in frequency; i.e., a lower input frequency produces a higher output frequency.

F4 is a YIG-tuned filter preselector that can be switched in or out of the circuit, depending upon the demands of the application. It blocks images and other unwanted responses at the expense of a degraded noise figure and dynamic range. Its use limits the passband of the 1313B to approximately 40 MHz.

F5 consists of a series of low-pass filters and amplifiers which limit the response to a maximum frequency of 425 MHz.

THE OUTPUT SECTION

Regardless of source, the 1313B has three outputs: Primary, Auxiliary, and Video. Note that the Auxiliary Output cannot be used in conjunction with the Bypass RF Path.

PRIMARY OUTPUT PATH

The center frequency and bandwidth of the primary output, IF1 in Figure 4-4, depend upon the input path selected. The nominal output frequency is 250 MHz. The actual frequency is determined by the center frequency of the input signal and the frequencies of the Local Oscillator signals applied. When the Primary Output is connected to the Bypass Input, there is no conversion or filtering in the line. Consequently, the output signal is simply the input signal amplified by a nominal 38 dB.

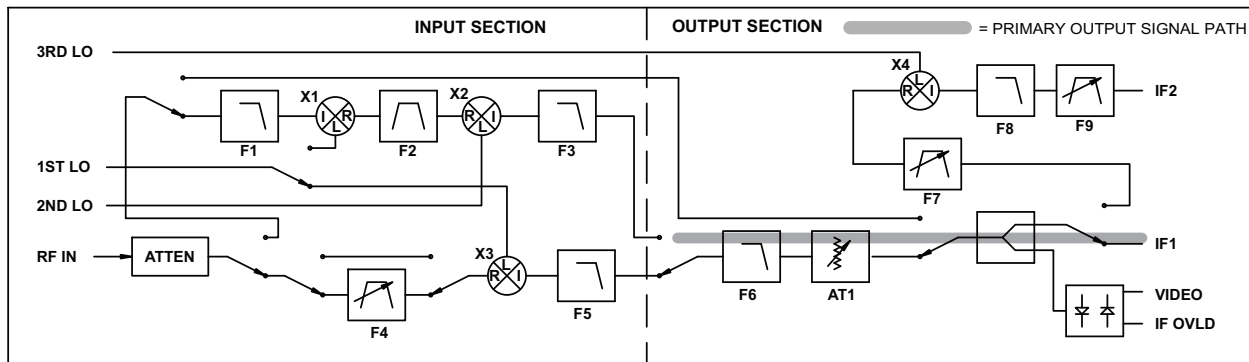

Figure 4-4. Primary Output Signal Path (IF1)

When the Primary Output is connected to either the Low Band or High Band input path, Filter F6 limits the maximum frequency passed to 425 MHz.



AUXILIARY OUTPUT PATH

The Auxiliary Output Path (Figure 4-5) produces a narrow-band output centered on 21.4 MHz. Its principal usefulness is in the generation of a Spectrum Analyzer display where the First LO frequency is swept (along with the YIG filter, F4, if appropriate), and the resolution bandwidth of the system is set by the bandwidth of switchable filter F9. Any of four filters can be selected as F9, giving bandwidths of 8 MHz, 2 MHz, 500 KHz, or 50 KHz.

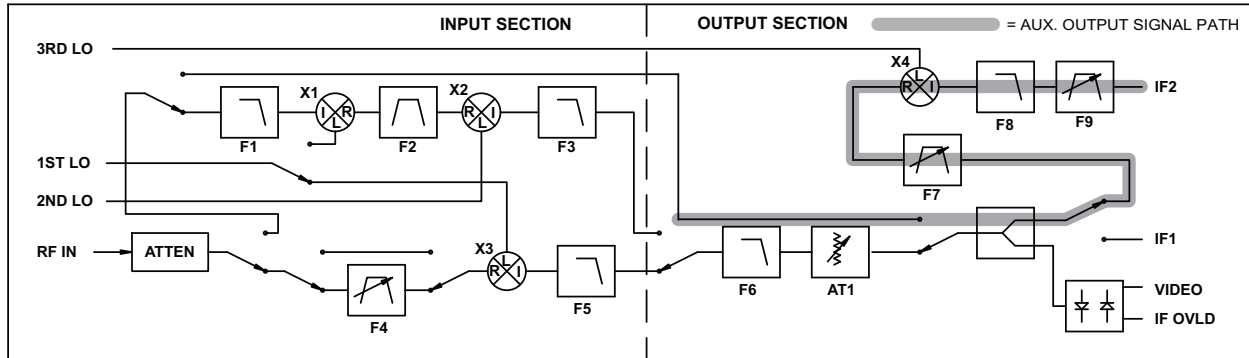

Figure 4-5. Auxiliary Output Signal Path (IF2)

The Video Output Path is enabled at all times, regardless of whether the Primary or Auxiliary output paths are selected. The Video Output is a DC level which is representative of the total signal contained within the (IF1) passband of the system.

DETAILED CIRCUIT DESCRIPTIONS

NOTE

The reference designators used in the detailed descriptions of the various circuit paths within the 1313B are the reference designators actually used in the device documentation. It should be noted that these reference designators, in general, are assigned to correspond to the physical location of the various components within the unit, not to any orderly progression by their function.

Numerous attenuators are shown in the detailed block diagrams referenced in the detailed circuit descriptions, but they are not otherwise discussed. These attenuators function primarily to improve the impedance match between active components (amplifiers, mixers, etc.) and reactive components (filters, etc.).

THE BYPASS PATH

The 1313B is normally operated in Bypass mode when it is desired to process signals of less than 100 MHz. Although the Bypass Signal Path (Figure 4-6) is only specified down to 1 MHz, it is generally usable at frequencies somewhat less than 100 KHz. Since there are no conversions or, in effect, filtering in the path, the output is identical to the input, amplified by a nominal 38 dB (49 dB of gain less 11 dB of internal path loss).

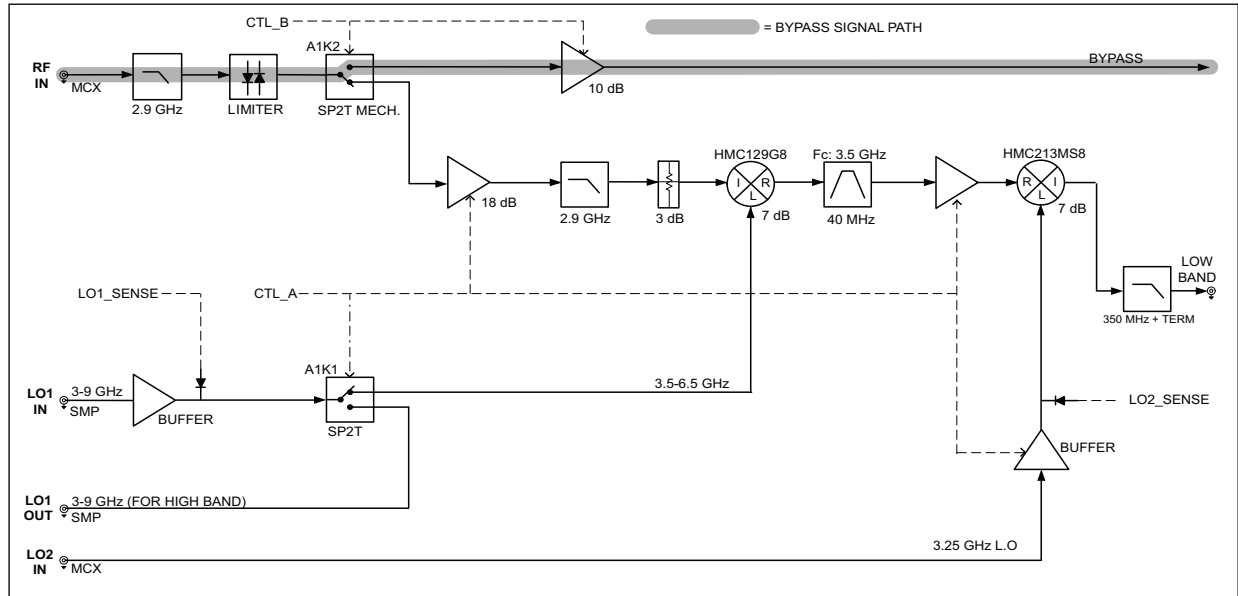

Figure 4-6. Bypass Signal Path

The 1313B is designed such that an input signal of -40 dBm produces a -2 dBm output with Attenuator Assembly A3 set to 0 dB. (The setting of attenuation, selection of paths, and other control issues are discussed in Section 6, “Operation and Programming.”)

CAUTION



The input circuitry of the 1313B can be damaged if the input signal level exceeds $+30$ dBm while the attenuator is set to 10 dB or greater or if the input signal level exceeds $+20$ dBm while the attenuator is set to 0 dB.

NOTE



The maximum recommended output level is -2 dBm (input -40 dBm with 0 dB attenuation.)



The Input Section of the Bypass Path is physically located on the A1 Low Band board.

Relay A7K0 selects either the Low Band/Bypass Path or the High Band Path.

The Bypass Path shares the LPF and Limiter with the Low-Band Path. The cutoff frequency of LPF is far above any frequency at which the Bypass Path might be used, and it can be ignored. The Limiter is to protect the amplifiers from an overpower condition.

Relay A1K2 selects either the Low Band or Bypass Path.

The amplifier boosts the signal to a total of 10 dB. The internal path loss is approximately 10 dB, giving a net gain of 0 dB with the attenuator set to 0 dB.

The Auxiliary Output, IF2, cannot be used with the Bypass Path.

THE LOW BAND PATH

The Low Band Signal Path (shown in Figure 4-7) is used to process signals in the frequency range of 100 MHz to 2.9 GHz. It is designed to convert the incoming signal to a 250 MHz output IF (IF1) and to have, in conjunction with the output-section circuitry, a gain of +38 dB. An input signal of -40 dBm produces an output of -2 dBm at IF1.

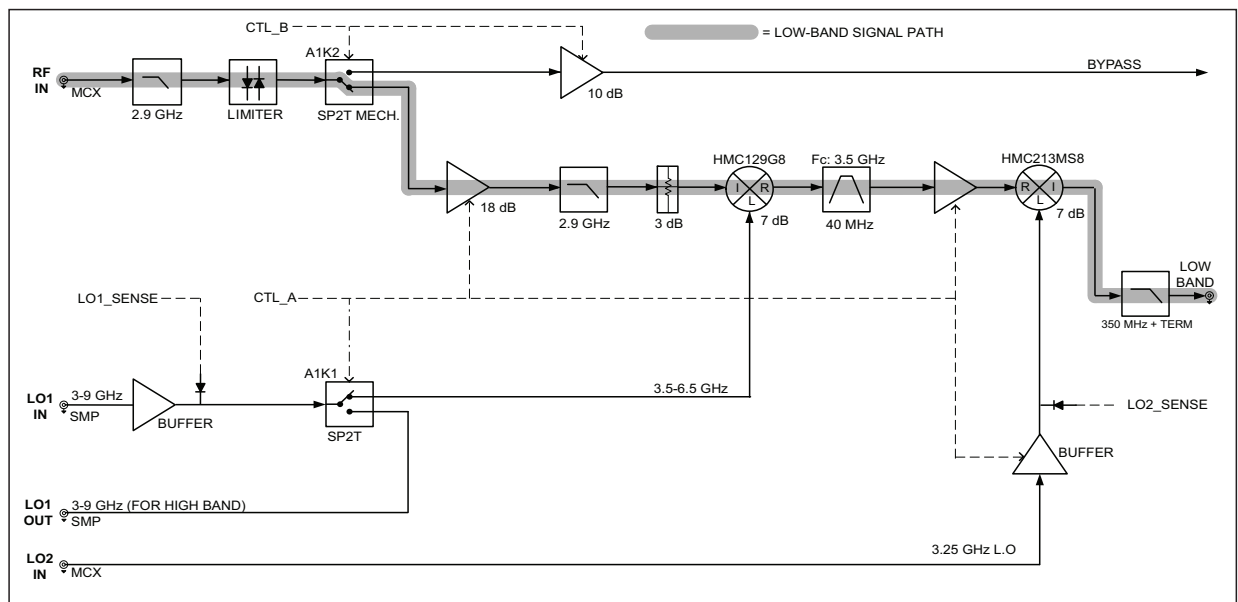

Figure 4-7. Low Band Signal Path

The Low-Band Path is a dual-conversion system. The first mixer utilizes high-side LO injection, which causes a frequency inversion. The second mixer utilizes low-side LO injection, which does not invert the signal. Therefore, the output of the Low-Band Path is inverted; i.e., a deviation of the input to a higher frequency causes a deviation of the output to a lower frequency.

Step Attenuator A3 provides attenuation of 0 to 70 dB in 10 dB steps. This allows for a maximum input signal of -40 dBm (with 0 dB attenuation) to +30 dBm (with 70 dB attenuation).

CAUTION

The input circuitry of the 1313B may be damaged if the input signal level exceeds +30 dBm while the attenuator is set to 10 dB or greater or if the input signal level exceeds +20 dBm while the attenuator is set to 0 dB.

NOTE

The maximum recommended output level is -2 dBm (input -40 dBm with 0 dB attenuation).

Relay A7K0 selects either the Low-Band/Bypass Path or the High-Band Path.

The Low-Band Path shares the LPF and Limiter with the Bypass Path. The Low-Pass filter LPF serves two functions. While it attenuates any out-of-band high-frequency signals, which might interfere with the operation of the Low-Band Path, its primary function is to attenuate any LO1 signal that might appear on the input connection.

The Limiter is to protect the amplifiers from an overpower condition.

Relay A1K2 selects either the Low Band or Bypass Path.

The first Amplifier is a relatively low-noise amplifier, which in addition to partially overcoming the losses of the passive components, essentially sets the noise figure of the Low-Band Path. The Low-Pass filter attenuates out-of-band signals and reduces the level of any LO1 signal appearing at the input connection.

An externally generated First LO signal 3.5 GHz above the frequency of interest tunes the 1313B Low Band. The Buffer Amplifier increases the level of the LO1 signal to overcome the losses of the relay A1K1 and the losses inherent in the internal microwave transmission lines to deliver a sufficient LO level to the mixer to ensure optimum performance. The 1313B is designed to operate with a +10 dBm minimum (+13 dBm nominal) LO1 signal applied.

The Band-Pass Filter Block at the output of the first mixer functions as an IF strip that has a very flat response centered on 3.5 GHz and is 40 MHz (1 dB bandwidth) wide with a very sharp cutoff. This IF strip sets the maximum bandwidth (the IF1 output bandwidth) of the Low Band and very sharply attenuates any out-of-band and image responses. It has an overall gain of 9 dB to provide an optimum signal level to the second mixer to maximize its dynamic range consistent with satisfactory intermodulation performance.

The Buffer Amplifier increases the level of the LO2 signal to a level that ensures optimum performance of the second mixer. The 1313B is designed to operate with a nominal +10 dBm LO2 signal applied.

The Low-Pass Filter attenuates the higher frequency products of the second mixer. The overall gain of the Low-Band Path is 10 dB.



THE HIGH BAND PATH

The High Band Signal Path (Figure 4-8) processes signals in the range of 2.7 GHz to 26.5 GHz. (Frequencies between 2.7 GHz and 2.9 GHz can be processed through either the Low Band Path or the High Band Path.) The High Band Path is designed to convert the incoming signal to a 250 MHz output IF (IF1) and to have, in conjunction with the output-section circuitry, a gain of +38 dB. An input signal of -40 dBm produces an output of -2 dBm at IF1.

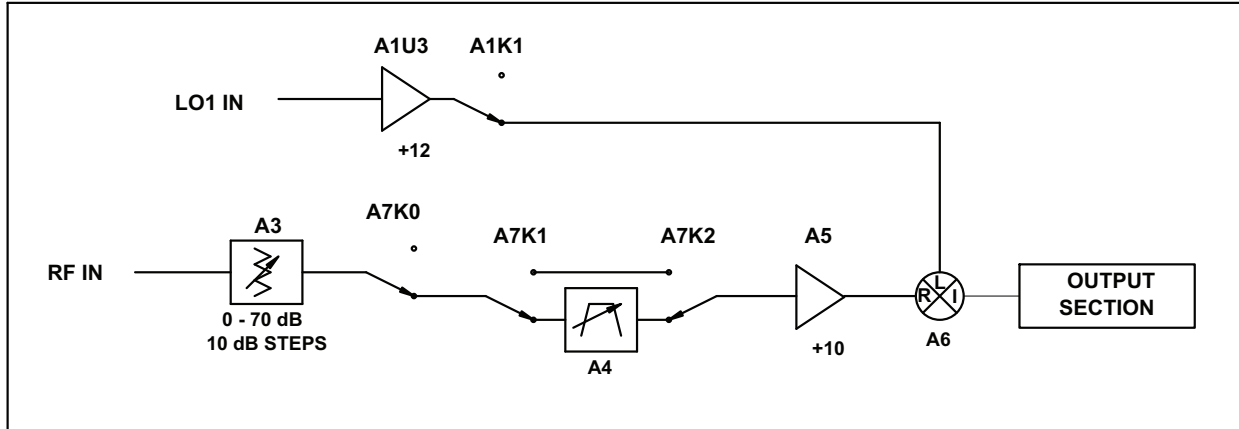

Figure 4-8. High Band Signal Path

Mixer A6 utilizes high-side LO injection, which causes a frequency inversion; i.e., a deviation of the input to a higher frequency causes a deviation of the output to a lower frequency.

Step Attenuator A3 provides attenuation of 0 to 70 dB in 10 dB steps. This allows for a maximum input signal of -40 dBm (with 0 dB attenuation) to +30 dBm (with 70 dB attenuation).

CAUTION



The input circuitry of the 1313B can be damaged if the input signal level exceeds +30 dBm while the attenuator is set to 10 dB or less if the input signal level exceeds +20 dBm while the attenuator is set to 0 dB.

Relay A7K0 selects either the Low Band/Bypass Path or the High Band Path.

A4 is a YIG-tuned filter, tunable over a range of 2.7 GHz to 26.5 GHz (see Section 6, “Operation and Programming,” and Section 7, “Calibration”). Its nominal bandwidth is 40 MHz, which sets the bandwidth of the output (IF1) when the 1313B is used in the YIG-tuned High Band mode.

Relays A7K1 and A7K2 establish a bypass path around the YIG. When the YIG is bypassed, the bandwidth of the path is set by the Output Section. The insertion loss of the YIG-tuned filter is 6 dB. Therefore, utilizing this bypass results in a 6 dB improvement in the noise figure of the system at the expense of selectivity.

A5 is a low noise amplifier having a gain of +10.

Mixer A6 is an X1/X3 device. It outputs an IF that is the difference between the input signal and the LO frequency as well as an IF that is the difference between the input signal and three times the LO frequency. X1 mixing is used at frequencies below 8.75 GHz, and X3 mixing is used at higher frequencies. Both of these mixing products are produced simultaneously. Since the conversion loss in the X1 mode is 8 dB, and the conversion loss in the X3 mode is 20 dB, the user must be aware of the possibility of spurious signals at approximately one third the frequency of the signal of interest when operating the 1313B above 8.75 GHz with the YIG-tuned filter bypassed.

The High Band Path shares A1U3 and A1K1 with the Low Band Path. A1U3 amplifies and A1K1 switches LO1 to the appropriate (Low Band or High Band) mixer.

THE OUTPUT SECTION

The Output Section (Figure 4-9) resides principally on assembly A2. It provides final filtering and gain control of the various RF paths, connecting them to the primary (IF1) or auxiliary (IF2) outputs and to the video detector circuitry. Both the High Band and Low Band Paths are connected through 3 dB pads, the principal function of which is to improve the impedance match, and 650 MHz low-pass filters, which help to suppress any residual local-oscillator signals. The High Band and Low Band inputs are at a nominal 250 MHz. Additionally, A2U24 and A2U23 add gain to the High Band Path to overcome the conversion loss of the High Band mixer, A6 (see “The High Band Path” on page 4-10).

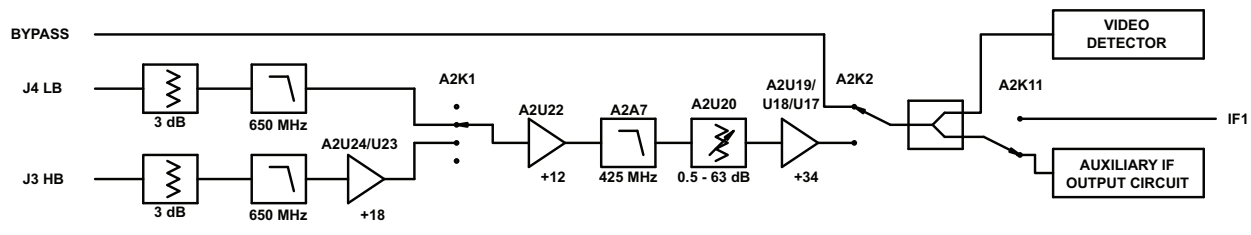

Figure 4-9. Output Section

A2K1 selects between the High Band Path and the Low Band Path.

The circuit segment consisting of A2U22, A2A7, A2U20, and the amplifier string, A2U19, U18, and U17 perform two functions. The primary purpose of Low Pass Filter A2U7 is anti-aliasing in a 1 GHz digitizer. It also suppresses local-oscillator leakage. In the case of the High Band Path with the YIG-tuned filter switched out of the circuit, it provides image suppression. It also limits the maximum frequency of the High and Low Band Paths to 425 MHz. This limits the range of IF frequency deviation from the 250 MHz nominal, which may be achieved by suitable adjustment of the LO1 and LO2 frequencies in the Low Band Path, and limits the bandwidth of the High Band Path when operated with the YIG-tuned filter bypassed. The second function of this circuit segment is gain control. A2U20 is a digitally controlled step attenuator which has a range of 0 dB



to 63 dB in half dB steps. Its attenuation may be set to control the overall system gain of the 1313B (see Section 6, “Operation and Programming,” and Section 7, “Calibration”).

Relay A2K2 selects between the Bypass Input Path and the Low/High Band Input Path. A resistive coupler sends a sample of the output to the Video Detector, discussed below and to Relay A2K11, which sends the output to either the Primary Output (IF1) or to the Auxiliary IF Output Circuit, discussed below.

THE VIDEO DETECTOR

A resistive splitter located between relays A2K2 and A2K11 in the output section (Figure 4-10) sends a sample of the output to amplifiers A2U16 and A2U15, which have a combined gain of 29 dB. The output of the amplifier is applied to the detector, A2D4 and A2D5, which produce a DC voltage proportional to the instantaneous amplitude of the output signal. This voltage is amplified in A2U11, a DC amplifier designed for unity gain into a 50 ohm load. The DC output level is monitored by a comparator, A2U10, which generates a flag indicating an overload condition. This flag can be read by the host computer (see Section 4, “Operation and Programming”).

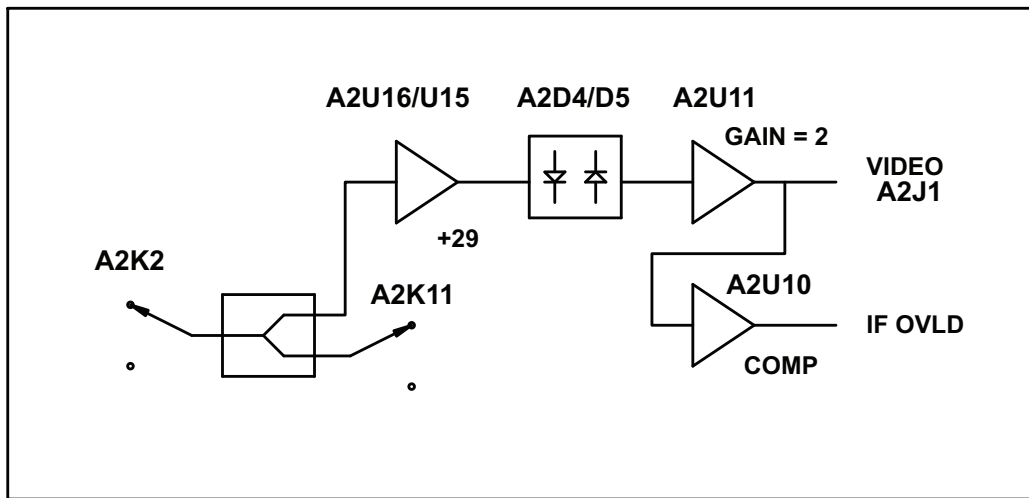

Figure 4-10. Video Detector Circuit

AUXILIARY IF OUTPUT

The Auxiliary Output Circuit (Figure 4-11) generates a narrow-band IF centered on 21.4 MHz. It requires a 249.4 MHz input with a minimum bandwidth of 8 MHz. It therefore cannot be used with the Bypass Input Path. When used with the High Band or Low Band Path, LO1 and LO2 frequencies must be chosen to produce a 249.4 MHz IF; i.e., the recommended LO frequencies must be used. The Auxiliary Output Circuit also requires a 228 MHz LO3 signal at a nominal 0 dBm. LO1 and LO2 frequencies may be chosen that produce a 250 MHz IF if a 228.4 MHz LO3 is used.

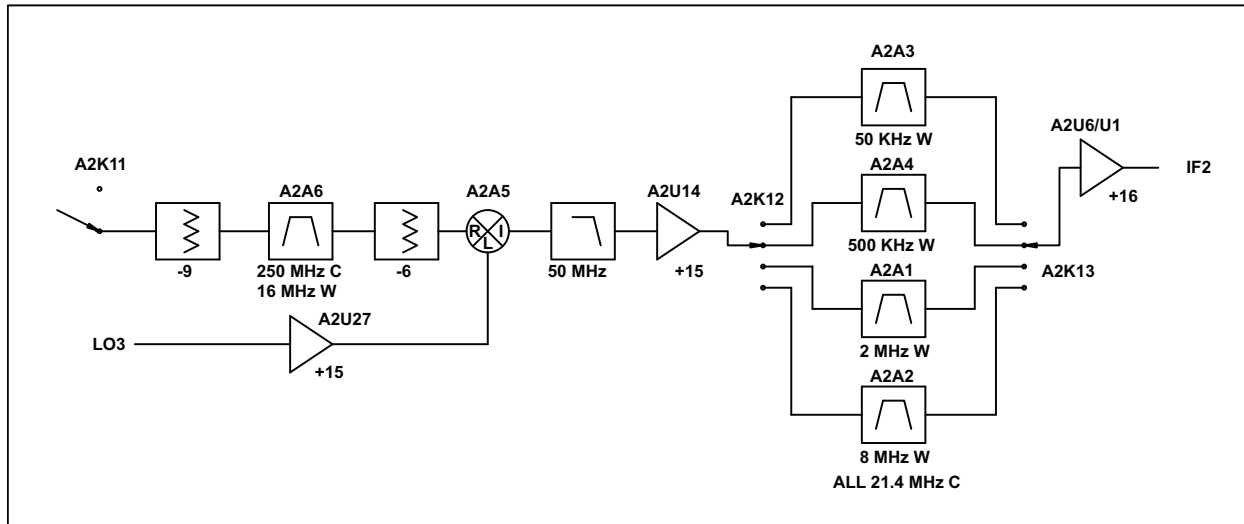

Figure 4-11. Auxiliary Output Circuit

Bandpass filter A2A6 provides rejection of image signals which fall within the passband of the wideband IF (IF1). It is isolated from the input and the mixer by resistive attenuators for impedance-matching purposes.

Amplifier A2U27 increases the amplitude of the LO3 signal to an appropriate level for the mixer, A2A5.

A 50 MHz LC low-pass filter attenuates the higher frequency products of the mixer. The signal is then amplified by A2U14. Relays A2K12 and A2K13 select one of four bandpass filters that set the passband of the Auxiliary Output IF (IF2). Bandwidths of 50 KHz, 500 KHz, 2 MHz, and 8 MHz are available. When the 1313B is used in the typical application, wherein the output is digitized to create a spectrum analyzer display, these filters select the resolution bandwidth of the virtual spectrum analyzer thus created.

Amplifier string A2U6 and A2U1 raise the output level such that the overall system gain is 38 dB.

Since the Auxiliary Output Circuit utilizes low-side LO injection, it does not invert the frequency of the signal. However, as noted above in the sections on the High and Low Band Paths, since both of these input sections do invert the signal, the output IF2 is inverted; i.e., an increase in input signal frequency results in a decrease in output signal frequency.



VXIbus INTERFACE AND CONTROL

The 1313B Interface and Control module (Figure 4-12) carries all of the logic circuitry to communicate with the controller via the VXI bus and to control the RF circuitry. It also contains the voltage regulators. Central to the Interface and Control module is the VXI-Bus Interface IC, IT9010. It performs all of the communications functions necessary to incorporate the 1313B into a VXI environment and, in conjunction with a Programmable Logic Device (PLD), controls the RF circuitry. Use of a register-based programming system obviates the need for a processor with its attendant hardware and software overhead.

NOTE



When hexadecimal numbers are used in this manual, they are indicated by appending a subscript "HEX" to the number.

Example: 3E0_{HEX} or 0921_{HEX}

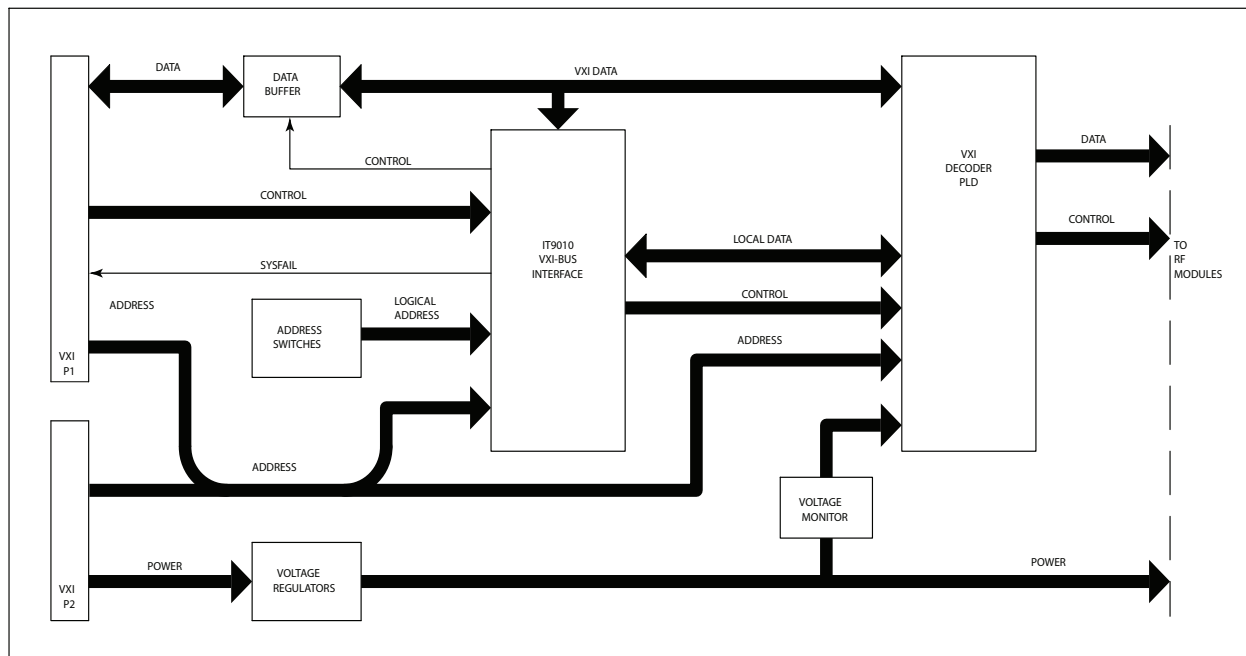

Figure 4-12. Interface and Control

Other than the special case of a SYSFAIL alert, the Interface and Control module has no capability of initiating communication with the rest of the VXI system. It reacts and responds only to commands sent to it. Any data it reports to the system controller is in direct response to a query from the controller. In addition to certain operational status reports, it can also report the Phase Matrix VXI Identifier Code, 3680 (E60_{HEX}), and the model of the unit, 1313 (521_{HEX}), information which is stored in the PLD.

Commands are sent to the 1313B by writing an appropriate number (data) to an appropriate register (address).

The 1313B utilizes both A16 and A24 addressing. The A16 address space contains the information used in initializing the system. The A24 address space contains the command and response information which is used to control the 1313B.

When the 1313B is installed, address switches are set to the logical address of the unit (see Section 2, "Installation"). During initialization, the VXI controller reads the logical address. From this, it calculates a base address for the A16 address space. The actual A16 registers are identified in the host computer as offsets to this base address. The user needs only to program these offsets. The VXI system controller (Slot 0 card) adds the base to the offset to generate the complete address.

In the initialization process, the VXI system controller reads the memory requirement of the 1313B (and all other units in the VXI system) and calculates and assigns a base address for the A24 address space, which is stored in the Offset Register.

When programming the 1313B, a register is identified by an Offset Address. When the host computer sends a command to the unit, the VXI controller concatenates the Offset Register value with the Offset Address of the particular command. The result is the complete address of the appropriate A24 register in the 1313B.

Data communication between the 1313B and the rest of the VXI system is controlled by a bi-directional Data Buffer which connects the 1313B internal data bus to the VXI data bus in the appropriate (read/write) direction under the control of the VXI Interface IC which, in turn, is responding to a command from the VXI system controller. Both the VXI Interface IC and the PLD can read from or write to the bus. Additionally, there is a local bus between the VXI Interface IC and the PLD that is under the control of the VXI Interface IC.

Data and control to the RF circuitry originates in the PLD and is supplied to the various switches and logically controllable devices in response to commands sent to the PLD registers by the VXI System Controller.

Additionally, the outputs of the voltage regulators are monitored and an error signal is sent to the PLD should any of the voltages become out of tolerance.

INITIALIZATION AND RESETS

The 1313B does not automatically initialize to any predetermined state. Hence, on initial start-up or after a system reset, it retains nothing of its previous operating state. The unit starts in a pseudo-random state and its outputs are not, generally speaking, usable; i.e., the outputs do not match the input requirements of the companion 20309 until both units are initialized by writing the necessary state data to the instruments' A24 addresses.



This Page Intentionally Left Blank

5

DRIVER PROGRAMMING

INTRODUCTION

The 1313B instrument driver provides programming support for Phase Matrix's 1313B VXIbus Microwave Downconverter. It contains functions for opening, configuring, taking measurements from, and closing the instrument. The information herein describes each function of the driver. The functions appear in alphabetical order with a description of the function and its C syntax, a description of each parameter, and a list of possible error codes.

NOTE

The 1313B instrument driver is available on the Phase Matrix website (www.phasematrix.com). The information in this chapter may not be current with the most recent driver.

The driver is divided into the following functions and classes:

1. Initialize:

This function initializes the instrument and sets it to a default configuration.

2. Application Functions: (Class)

This class contains high-level test and measurement routines. These examples call other instrument driver functions to configure, start, and read from the instrument.

3. Configuration Functions: (Class)

This class of functions configures the instrument by setting acquisition and system configuration parameters.

4. Action/Status Functions: (Class)

This class of functions begins or terminates an acquisition. It also provides functions that allow the user to determine the current status of the instrument.



5. Data Functions: (Class)

This class of functions transfers data to or from the instrument.

6. Utility Functions: (Class)

This class of functions provides lower level functions to communicate with the instrument, and change instrument parameters.

7. Close:

This function takes the instrument offline.

REQUIREMENTS

To successfully use the 1313B instrument module, the following conditions must be met:

- For GPIB instrument drivers:
 - the instrument is connected to the GPIB.
 - the GPIB address supplied to the initialize function must match the GPIB address of the instrument.
- For VXI instrument drivers:
 - the instrument is installed in the VXI mainframe and one of the following controller options is being used:
 - Embedded controller
 - MXI
 - MXI2
 - GPIB-VXI
 - the logical address supplied to the initialize function must match the logical address of the instrument.
- For RS-232 instrument drivers:
 - the instrument is connected to the RS-232 interface.
 - the COM port, baud rate, parity, and timeout supplied to the initialize function must match the settings of the instrument.

ERROR AND STATUS INFORMATION

Each function in the driver returns a status code that either indicates success or describes an error or warning condition. The status code from each call to a driver function should be examined to determine if an error has occurred within the developed program. The description of each instrument driver function lists possible error codes and their meanings. The general meaning of the status code is as follows:

<u>Value</u>	<u>Meaning</u>
0	Success
Positive Values	Warnings
Negative Values	Errors



FUNCTIONS

PM1313B_CLOSE

```
ViStatus PM1313B_close (ViSession instrumentHandle);
```

PURPOSE

This function performs **viClose (instrSession)** and **viClose (rmSession)**.

NOTE

The instrument must be reinitialized in order to use it again.

PARAMETER LIST

instrumentHandle

Variable Type: **ViSession**

This control accepts the **InstrumentHandle** returned by the **Initialize** function to select the desired instrument driver session.

Default Value: None

RETURN VALUE

Every driver function returns a status value that indicates whether or not the function was executed successfully.

Normal Return: **VI_SUCCESS**

Error Return: Call function **pm1313b_error_message ()** to get the message this code represents.

PM1313B_ERRORMESSAGE

```
ViStatus PM1313B_errorMessage (ViSession instrumentHandle, ViStatus errorCode,  
ViChar _VI_FAR errorMessage[]);
```

PURPOSE

This function takes the status code returned by the instrument driver functions, interprets it, and returns it as a user-readable string.

PARAMETER LIST

instrumentHandle

Variable Type: **ViSession**

This control accepts the **InstrumentHandle** returned by the **Initialize** function to select the desired instrument driver session.

Default Value: **VI_NULL**

errorCode

Variable Type: **ViStatus**

This control accepts the status code returned from the instrument driver functions.

Default Value: **0 - VI_SUCCESS**

errorMessage

Variable Type: **ViChar[]**

This control returns the interpreted status code as a user readable message string.

NOTE

The array must contain at least 256 elements ViChar[256].

RETURN VALUE

Every driver function returns a status value that indicates whether or not the function was executed successfully.

Normal Return: **VI_SUCCESS**

Error Return: Call function **pm1313b_error_message ()** to get the message this code represents.



PM1313B_GET_STATUS

```
ViStatus PM1313B_get_status (ViSession instrumentHandle, ViChar _VI_FAR  
instrumentStatus[]);
```

PURPOSE

This function reads the instrument's status. A high bit indicates that the corresponding hardware is functional.

Status Strings:

0. +10 Volt Supply (VXI Power Supply Voltage)
1. +21 Volt Supply (VXI Power Supply Voltage)
2. -21 Volt Supply (VXI Power Supply Voltage)
3. -10 Volt Supply (VXI Power Supply Voltage)
4. +5 Volt Supply (VXI Power Supply Voltage)
5. Always high (Not used)
6. Always high (Not used)
7. Always high (Not used)
8. L.O. 1 SENSE (Indicates that the 3-9 GHz LO is present, Low-Band module A1)
9. L.O. 2 SENSE (Indicates that the 3.25 GHz LO is present, Low-Band module A1)
10. L.O. 3 SENSE (Indicates that the 228 MHz LO is present, IF-Processor module A2)
11. Overload (Indicates that the IF section is being overdriven, IF-Processor Module A2)
12. Always high (Not used)
13. Always high (Not used)
14. Always high (Not used)
15. Always high (Not used)

PARAMETER LIST

instrumentHandle

Variable Type: **ViSession**

This control accepts the **InstrumentHandle** returned by the **Initialize** function to select the desired instrument driver session.

Default Value: None

instrumentStatus

Variable Type: **viChar[]**

This control displays the current status of the instrument.

Status Strings:

0. +10 Volt Supply
1. +21 Volt Supply
2. -21 Volt Supply
3. -10 Volt Supply
4. +5 Volt Supply
5. Not used
6. Not used
7. Not used
8. L.O. 1 SENSE
9. L.O. 2 SENSE
10. L.O. 3 SENSE
11. Overload
12. Not used
13. Not used
14. Not used
15. Not used

RETURN VALUE

Every driver function returns a status value that indicates whether or not the function was executed successfully.

Normal Return: **VI_SUCCESS**

Error Return: Call function **pm1313b_error_message()** to get the message this code represents.



PM1313B_INIT

```
ViStatus PM1313B_init (ViRsrc resourceName, ViBoolean IDQuery, ViBoolean  
reset, ViPSession instrumentHandle, ViPInt16 model);
```

PURPOSE

This function performs the following initialization actions:

- Opens a session to the default resource manager resource and a session to the specified device using the interface and address specified in the **Resource_Name** control.
- Performs an identification query on the instrument.
- Resets the downconverter YIG, IF attenuators, RF step attenuator, and signal path to a known state.
- Sends initialization commands to the instrument that set any necessary programmatic variables such as headers off, short command form, and data transfer binary to the state necessary for the operation of the instrument driver.
- Returns an **InstrumentHandle** that is used to differentiate between different sessions of the instrument driver.

NOTE

Each time this function is invoked, a unique session is opened. It is possible to have more than one session open for the same resource.

PARAMETER LIST

resourceName

Variable Type: **ViRsrc**

This control specifies the interface and address of the device that is to be initialized (instrument descriptor). The exact grammar to be used in this control is shown below.

Default Value: "**GPIB::1**"

NOTE

Based on the instrument descriptor, this operation establishes a communication session with a device. The grammar for the instrument descriptor is shown below. Optional parameters are shown in square brackets ([]).

Interface Grammar

GPIB GPIB[board]::primary address[::secondary address][::INSTR]

The GPIB keyword is used with GPIB instruments. The default value for optional parameters are shown below.

<u>Optional Parameter</u>	<u>Default Value</u>
board	0
secondary address	none - 31

IDQueryVariable Type: **ViBoolean**

This control specifies if an ID query is sent to the instrument during the initialization procedure.

Valid Range:

- VI_OFF (0) - Skip Query
- VI_ON (1) - Do Query (Default Value)

NOTE

Under normal circumstances, the ID query ensures that the instrument initialized is the type supported by this driver. However, circumstances may arise when it is undesirable to send an ID query to the instrument. In those cases, set this control to "Skip Query," and this function will initialize the selected interface without doing an ID query.

resetVariable Type: **ViBoolean**

This control specifies if a **reset** is sent to the instrument during the initialization procedure.

Valid Range:

- VI_OFF (0) - Skip Reset
- VI_ON (1) - Do Reset (Default Value)

instrumentHandleVariable Type: **ViSession** (passed by reference)

This control returns an **InstrumentHandle** that is used in all subsequent function calls to differentiate between different sessions of the instrument driver.



NOTE

Each time this function is invoked, a unique session is opened. It is possible to have more than one session open for the same resource.

model

Variable Type: **viInt16** (passed by reference)

RETURN VALUE

This control contains the status code returned by the function call.

Status Codes:

<u>Status</u>	<u>Description</u>
0	No error (the call was successful).
3FFC0101	ID Query not supported - VI_WARN_NSUP_ID_QUERY
3FFC0102	Reset not supported - VI_WARN_NSUP_RESET
3FFC0103	Self Test not supported - VI_WARN_NSUP_SELF_TEST
3FFC0104	Error Query not supported - VI_WARN_NSUP_ERROR_QUERY
3FFC0105	Revision Query not supported - VI_WARN_NSUP_REV_QUERY
3FFF0005	The specified termination character was read.
3FFF0006	The specified number of bytes was read.
BFFC0001	Parameter 1 out of range. (String not range checked)
BFFC0002	Parameter 2 (ID Query) out of range.
BFFC0003	Parameter 3 (Reset Device) out of range.
BFFC0004	Parameter 4 out of range.
BFFC0005	Parameter 5 out of range.
BFFC0006	Parameter 6 out of range.
BFFC0007	Parameter 7 out of range.
BFFC0008	Parameter 8 out of range.
BFFC0011	Instrument returned invalid response to ID Query
BFFC0800	Error Opening File VI_ERROR_INSTR_FILE_OPEN
BFFC0801	Error Writing to File VI_ERROR_INSTR_FILE_WRITE
BFFC0803	Invalid Response VI_ERROR_INSTR_INTERPRETING_RESPONSE
BFFC0809	Parameter 9 out of range. VI_ERROR_INSTR_PARAMETER9
BFFC080A	Parameter 10 out of range. VI_ERROR_INSTR_PARAMETER10
BFFC080B	Parameter 11 out of range. VI_ERROR_INSTR_PARAMETER11
BFFC080C	Parameter 12 out of range. VI_ERROR_INSTR_PARAMETER12

BFFF0000	Miscellaneous or system error occurred.
BFFF000E	Invalid session handle.
BFFF0015	Timeout occurred before operation could complete.
BFFF0034	Violation of raw write protocol occurred.
BFFF0035	Violation of raw read protocol occurred.
BFFF0036	Device reported an output protocol error.
BFFF0037	Device reported an input protocol error.
BFFF0038	Bus error occurred during transfer.
BFFF003A	Invalid setup (attributes are not consistent).
BFFF005F	No listeners condition was detected.
BFFF0060	This interface is not the controller in charge.
BFFF0067	Operation is not supported on this session.



PM1313B_PWR_CAL

ViStatus PM1313B_pwr_cal (ViSession instrumentHandle);

PURPOSE

This function performs power sensor calibration using a NIST-traceable reference port.

PARAMETER LIST

instrumentHandle

Variable Type: **ViSession**

This control returns an **InstrumentHandle** that is used in all subsequent function calls to differentiate between different sessions of the instrument driver.

NOTE

Each time this function is invoked, a unique session is opened. It is possible to have more than one session open for the same resource.

RETURN VALUE

This control contains the status code returned by the function call.

Status Codes:

<u>Status</u>	<u>Description</u>
0	No error (the call was successful).
3FFC0101	ID Query not supported - VI_WARN_NSUP_ID_QUERY
3FFC0102	Reset not supported - VI_WARN_NSUP_RESET
3FFC0103	Self Test not supported - VI_WARN_NSUP_SELF_TEST
3FFC0104	Error Query not supported - VI_WARN_NSUP_ERROR_QUERY
3FFC0105	Revision Query not supported - VI_WARN_NSUP_REV_QUERY
3FFF0005	The specified termination character was read.
3FFF0006	The specified number of bytes was read.
BFFC0001	Parameter 1 out of range. (String not range checked)
BFFC0002	Parameter 2 (ID Query) out of range.
BFFC0003	Parameter 3 (Reset Device) out of range.
BFFC0004	Parameter 4 out of range.
BFFC0005	Parameter 5 out of range.
BFFC0006	Parameter 6 out of range.



BFFC0007	Parameter 7 out of range.
BFFC0008	Parameter 8 out of range.
BFFC0011	Instrument returned invalid response to ID Query
BFFC0800	Error Opening File VI_ERROR_INSTR_FILE_OPEN
BFFC0801	Error Writing to File VI_ERROR_INSTR_FILE_WRITE
BFFC0803	Invalid Response VI_ERROR_INSTR_INTERPRETING_RESPONSE
BFFC0809	Parameter 9 out of range. VI_ERROR_INSTR_PARAMETER9
BFFC080A	Parameter 10 out of range. VI_ERROR_INSTR_PARAMETER10
BFFC080B	Parameter 11 out of range. VI_ERROR_INSTR_PARAMETER11
BFFC080C	Parameter 12 out of range. VI_ERROR_INSTR_PARAMETER12
BFFF0000	Miscellaneous or system error occurred.
BFFF000E	Invalid session handle.
BFFF0015	Timeout occurred before operation could complete.
BFFF0034	Violation of raw write protocol occurred.
BFFF0035	Violation of raw read protocol occurred.
BFFF0036	Device reported an output protocol error.
BFFF0037	Device reported an input protocol error.
BFFF0038	Bus error occurred during transfer.
BFFF003A	Invalid setup (attributes are not consistent).
BFFF005F	No listeners condition was detected.
BFFF0060	This interface is not the controller in charge.
BFFF0067	Operation is not supported on this session.



PM1313B_PWR_CAL_ALL

```
ViStatus PM1313B_pwr_cal_all (ViSession instrumentHandle);
```

PURPOSE

This function allows the user to perform power-sensor zeroing and calibration using a NIST-traceable reference port while the power sensor is connected to the reference.

PARAMETER LIST

instrumentHandle

Variable Type: **ViSession**

This control returns an **InstrumentHandle** that is used in all subsequent function calls to differentiate between different sessions of the instrument driver.

NOTE

Each time this function is invoked, a unique session is opened. It is possible to have more than one session open for the same resource.

RETURN VALUE

This control contains the status code returned by the function call.

Status Codes:

<u>Status</u>	<u>Description</u>
0	No error (the call was successful).
3FFC0101	ID Query not supported - VI_WARN_NSUP_ID_QUERY
3FFC0102	Reset not supported - VI_WARN_NSUP_RESET
3FFC0103	Self Test not supported - VI_WARN_NSUP_SELF_TEST
3FFC0104	Error Query not supported - VI_WARN_NSUP_ERROR_QUERY
3FFC0105	Revision Query not supported - VI_WARN_NSUP_REV_QUERY
3FFF0005	The specified termination character was read.
3FFF0006	The specified number of bytes was read.
BFFC0001	Parameter 1 out of range. (String not range checked)
BFFC0002	Parameter 2 (ID Query) out of range.
BFFC0003	Parameter 3 (Reset Device) out of range.
BFFC0004	Parameter 4 out of range.
BFFC0005	Parameter 5 out of range.



BFFC0006	Parameter 6 out of range.
BFFC0007	Parameter 7 out of range.
BFFC0008	Parameter 8 out of range.
BFFC0011	Instrument returned invalid response to ID Query
BFFC0800	Error Opening File VI_ERROR_INSTR_FILE_OPEN
BFFC0801	Error Writing to File VI_ERROR_INSTR_FILE_WRITE
BFFC0803	Invalid Response VI_ERROR_INSTR_INTERPRETING_RESPONSE
BFFC0809	Parameter 9 out of range. VI_ERROR_INSTR_PARAMETER9
BFFC080A	Parameter 10 out of range. VI_ERROR_INSTR_PARAMETER10
BFFC080B	Parameter 11 out of range. VI_ERROR_INSTR_PARAMETER11
BFFC080C	Parameter 12 out of range. VI_ERROR_INSTR_PARAMETER12
BFFF0000	Miscellaneous or system error occurred.
BFFF000E	Invalid session handle.
BFFF0015	Timeout occurred before operation could complete.
BFFF0034	Violation of raw write protocol occurred.
BFFF0035	Violation of raw read protocol occurred.
BFFF0036	Device reported an output protocol error.
BFFF0037	Device reported an input protocol error.
BFFF0038	Bus error occurred during transfer.
BFFF003A	Invalid setup (attributes are not consistent).
BFFF005F	No listeners condition was detected.
BFFF0060	This interface is not the controller in charge.
BFFF0067	Operation is not supported on this session.



PM1313B_PWR_CLS

```
ViStatus PM1313B_pwr_cls (ViSession instrumentHandle);
```

PURPOSE

This function clears the power meter.

PARAMETER LIST

instrumentHandle

Variable Type: **ViSession**

This control returns an **InstrumentHandle** that is used in all subsequent function calls to differentiate between different sessions of the instrument driver.

NOTE

Each time this function is invoked, a unique session is opened. It is possible to have more than one session open for the same resource.

RETURN VALUE

This control contains the status code returned by the function call.

Status Codes:

<u>Status</u>	<u>Description</u>
0	No error (the call was successful).
3FFC0101	ID Query not supported - VI_WARN_NSUP_ID_QUERY
3FFC0102	Reset not supported - VI_WARN_NSUP_RESET
3FFC0103	Self Test not supported - VI_WARN_NSUP_SELF_TEST
3FFC0104	Error Query not supported - VI_WARN_NSUP_ERROR_QUERY
3FFC0105	Revision Query not supported - VI_WARN_NSUP_REV_QUERY
3FFF0005	The specified termination character was read.
3FFF0006	The specified number of bytes was read.
BFFC0001	Parameter 1 out of range. (String not range checked)
BFFC0002	Parameter 2 (ID Query) out of range.
BFFC0003	Parameter 3 (Reset Device) out of range.
BFFC0004	Parameter 4 out of range.
BFFC0005	Parameter 5 out of range.
BFFC0006	Parameter 6 out of range.



BFFC0007	Parameter 7 out of range.
BFFC0008	Parameter 8 out of range.
BFFC0011	Instrument returned invalid response to ID Query
BFFC0800	Error Opening File. VI_ERROR_INSTR_FILE_OPEN
BFFC0801	Error Writing to File. VI_ERROR_INSTR_FILE_WRITE
BFFC0803	Invalid Response VI_ERROR_INSTR_INTERPRETING_RESPONSE
BFFC0809	Parameter 9 out of range. VI_ERROR_INSTR_PARAMETER9
BFFC080A	Parameter 10 out of range. VI_ERROR_INSTR_PARAMETER10
BFFC080B	Parameter 11 out of range. VI_ERROR_INSTR_PARAMETER11
BFFC080C	Parameter 12 out of range. VI_ERROR_INSTR_PARAMETER12
BFFF0000	Miscellaneous or system error occurred.
BFFF000E	Invalid session handle.
BFFF0015	Timeout occurred before operation could complete.
BFFF0034	Violation of raw write protocol occurred.
BFFF0035	Violation of raw read protocol occurred.
BFFF0036	Device reported an output protocol error.
BFFF0037	Device reported an input protocol error.
BFFF0038	Bus error occurred during transfer.
BFFF003A	Invalid setup (attributes are not consistent).
BFFF005F	No listeners condition was detected.
BFFF0060	This interface is not the controller in charge.
BFFF0067	Operation is not supported on this session.



PM1313B_PWR_DBM

```
ViStatus PM1313B_pwr_dbm (ViSession instrumentHandle);
```

PURPOSE

This function sets power meter units to dBm

PARAMETER LIST

instrumentHandle

Variable Type: **ViSession**

This control returns an **InstrumentHandle** that is used in all subsequent function calls to differentiate between different sessions of the instrument driver.

NOTE

Each time this function is invoked, a unique session is opened. It is possible to have more than one session open for the same resource.

RETURN VALUE

This control contains the status code returned by the function call.

Status Codes:

<u>Status</u>	<u>Description</u>
0	No error (the call was successful).
3FFC0101	ID Query not supported - VI_WARN_NSUP_ID_QUERY
3FFC0102	Reset not supported - VI_WARN_NSUP_RESET
3FFC0103	Self Test not supported - VI_WARN_NSUP_SELF_TEST
3FFC0104	Error Query not supported - VI_WARN_NSUP_ERROR_QUERY
3FFC0105	Revision Query not supported - VI_WARN_NSUP_REV_QUERY
3FFF0005	The specified termination character was read.
3FFF0006	The specified number of bytes was read.
BFFC0001	Parameter 1 out of range. (String not range checked)
BFFC0002	Parameter 2 (ID Query) out of range.
BFFC0003	Parameter 3 (Reset Device) out of range.
BFFC0004	Parameter 4 out of range.
BFFC0005	Parameter 5 out of range.
BFFC0006	Parameter 6 out of range.



BFFC0007	Parameter 7 out of range.
BFFC0008	Parameter 8 out of range.
BFFC0011	Instrument returned invalid response to ID Query
BFFC0800	Error Opening File VI_ERROR_INSTR_FILE_OPEN
BFFC0801	Error Writing to File VI_ERROR_INSTR_FILE_WRITE
BFFC0803	Invalid Response VI_ERROR_INSTR_INTERPRETING_RESPONSE
BFFC0809	Parameter 9 out of range. VI_ERROR_INSTR_PARAMETER9
BFFC080A	Parameter 10 out of range. VI_ERROR_INSTR_PARAMETER10
BFFC080B	Parameter 11 out of range. VI_ERROR_INSTR_PARAMETER11
BFFC080C	Parameter 12 out of range. VI_ERROR_INSTR_PARAMETER12
BFFF0000	Miscellaneous or system error occurred.
BFFF000E	Invalid session handle.
BFFF0015	Timeout occurred before operation could complete.
BFFF0034	Violation of raw write protocol occurred.
BFFF0035	Violation of raw read protocol occurred.
BFFF0036	Device reported an output protocol error.
BFFF0037	Device reported an input protocol error.
BFFF0038	Bus error occurred during transfer.
BFFF003A	Invalid setup (attributes are not consistent).
BFFF005F	No listeners condition was detected.
BFFF0060	This interface is not the controller in charge.
BFFF0067	Operation is not supported on this session.



PM1313B_PWR_DIAG

```
ViStatus PM1313B_pwr_Diag (ViSession instrumentHandle, ViUInt16  
pwrMtrDiagnostics, ViUInt16 optParam);
```

PURPOSE

This function enables the user to perform diagnostic functions.

Commands:

- 0 Execute power-up initialization of the power meter (assume it has been reset).
- 1 Send CLR command to PM.
- 2 Get a power reading, parse, and display it.
- 3 Wait for a reply message from the PM, and then dump the raw message.
- 4 Read the two handshake bytes and print the results.
- 5 Print the addresses of the DPR variables.
- 6 Perform DPR Memory Test.
- 7 Read PM_DPR_C_INT
- 8 Write PM_DPR_PM_INT
- 9 Initialize the **PmCmdMsg** Buffer.
- 10 Send dBm command to the power meter.
- 11 Send WATT command to the power meter.
- 12 Send ZERO command to the power meter.
- 13 Send CAL command to the power meter.
- 14 Send ZERO command to the power meter and wait for it to complete.
- 15 Send CS command to the power meter and wait for it to complete.
- 16 Toggle PM's Local/Remote Flag.



- 17 Send CLR command to PM.
- 18 Send PM OFF command to turn off the power meter.
- 19 Send Trigger Mode 0=hold, 1=immediate, 2=trigger with delay, or 3=continuous.
- 20 Initiate diagnostic self test #72.
- 21 Execute power-up initialization without self test.
- 22 Send OC1 command to turn on PWR REF
- 23 Send OC0 command to turn off PWR REF
- 24 Send LCL command.
- 25 Send PRESET command.
- 26 Send RANGE command to set manual or auto range.

PARAMETER LIST

instrumentHandle

Variable Type: **viSession**

This control returns an **InstrumentHandle** that is used in all subsequent function calls to differentiate between different sessions of the instrument driver.

NOTE

Each time this function is invoked, a unique session is opened. It is possible to have more than one session open for the same resource.

pwrMtrDiagnostics

Variable Type: **viUInt16**

optParam

Variable Type: **viUInt16**

RETURN VALUE

This control contains the status code returned by the function call.



Status Codes:

<u>Status</u>	<u>Description</u>
0	No error (the call was successful).
3FFC0101	ID Query not supported - VI_WARN_NSUP_ID_QUERY
3FFC0102	Reset not supported - VI_WARN_NSUP_RESET
3FFC0103	Self Test not supported - VI_WARN_NSUP_SELF_TEST
3FFC0104	Error Query not supported - VI_WARN_NSUP_ERROR_QUERY
3FFC0105	Revision Query not supported - VI_WARN_NSUP_REV_QUERY
3FFF0005	The specified termination character was read.
3FFF0006	The specified number of bytes was read.
BFFC0001	Parameter 1 out of range. (String not range checked)
BFFC0002	Parameter 2 (ID Query) out of range.
BFFC0003	Parameter 3 (Reset Device) out of range.
BFFC0004	Parameter 4 out of range.
BFFC0005	Parameter 5 out of range.
BFFC0006	Parameter 6 out of range.
BFFC0007	Parameter 7 out of range.
BFFC0008	Parameter 8 out of range.
BFFC0011	Instrument returned invalid response to ID Query
BFFC0800	Error Opening File VI_ERROR_INSTR_FILE_OPEN
BFFC0801	Error Writing to File VI_ERROR_INSTR_FILE_WRITE
BFFC0803	Invalid Response VI_ERROR_INSTR_INTERPRETING_RESPONSE
BFFC0809	Parameter 9 out of range. VI_ERROR_INSTR_PARAMETER9
BFFC080A	Parameter 10 out of range. VI_ERROR_INSTR_PARAMETER10
BFFC080B	Parameter 11 out of range. VI_ERROR_INSTR_PARAMETER11
BFFC080C	Parameter 12 out of range. VI_ERROR_INSTR_PARAMETER12
BFFF0000	Miscellaneous or system error occurred.
BFFF000E	Invalid session handle.
BFFF0015	Timeout occurred before operation could complete.
BFFF0034	Violation of raw write protocol occurred.
BFFF0035	Violation of raw read protocol occurred.
BFFF0036	Device reported an output protocol error.
BFFF0037	Device reported an input protocol error.
BFFF0038	Bus error occurred during transfer.



BFFF003A	Invalid setup (attributes are not consistent).
BFFF005F	No listeners condition was detected.
BFFF0060	This interface is not the controller in charge.
BFFF0067	Operation is not supported on this session.



PM1313B_PWR_DIAGDPRFILL

ViStatus PM1313B_pwr_DiagDprFill (ViSession instrumentHandle, unsigned char byTestValue);

PURPOSE

This function is utilized for diagnostic purposes. It tests one memory location at a time by writing the TestValue then comparing it to the value read back.

WARNING

Do not change addresses 0, 0x3fe, 0x3ff, 0x214, 0x215, 0x216, or 0x217 because they are part of Dual Port RAM's functionality.

PARAMETER LIST

instrumentHandle

Variable Type: **ViSession**

This control returns an **InstrumentHandle** that is used in all subsequent function calls to differentiate between different sessions of the instrument driver.

NOTE

Each time this function is invoked, a unique session is opened. It is possible to have more than one session open for the same resource.

byTestValue

Variable Type: **unsigned char**

RETURN VALUE

This control contains the status code returned by the function call.

Status Codes:

<u>Status</u>	<u>Description</u>
0	No error (the call was successful).
3FFC0101	ID Query not supported - VI_WARN_NSUP_ID_QUERY
3FFC0102	Reset not supported - VI_WARN_NSUP_RESET
3FFC0103	Self Test not supported - VI_WARN_NSUP_SELF_TEST
3FFC0104	Error Query not supported - VI_WARN_NSUP_ERROR_QUERY



3FFC0105	Revision Query not supported - VI_WARN_NSUP_REV_QUERY
3FFF0005	The specified termination character was read.
3FFF0006	The specified number of bytes was read.
BFFC0001	Parameter 1 out of range. (String not range checked)
BFFC0002	Parameter 2 (ID Query) out of range.
BFFC0003	Parameter 3 (Reset Device) out of range.
BFFC0004	Parameter 4 out of range.
BFFC0005	Parameter 5 out of range.
BFFC0006	Parameter 6 out of range.
BFFC0007	Parameter 7 out of range.
BFFC0008	Parameter 8 out of range.
BFFC0011	Instrument returned invalid response to ID Query
BFFC0800	Error Opening File VI_ERROR_INSTR_FILE_OPEN
BFFC0801	Error Writing to File VI_ERROR_INSTR_FILE_WRITE
BFFC0803	Invalid Response VI_ERROR_INSTR_INTERPRETING_RESPONSE
BFFC0809	Parameter 9 out of range. VI_ERROR_INSTR_PARAMETER9
BFFC080A	Parameter 10 out of range. VI_ERROR_INSTR_PARAMETER10
BFFC080B	Parameter 11 out of range. VI_ERROR_INSTR_PARAMETER11
BFFC080C	Parameter 12 out of range. VI_ERROR_INSTR_PARAMETER12
BFFF0000	Miscellaneous or system error occurred.
BFFF000E	Invalid session handle.
BFFF0015	Timeout occurred before operation could complete.
BFFF0034	Violation of raw write protocol occurred.
BFFF0035	Violation of raw read protocol occurred.
BFFF0036	Device reported an output protocol error.
BFFF0037	Device reported an input protocol error.
BFFF0038	Bus error occurred during transfer.
BFFF003A	Invalid setup (attributes are not consistent).
BFFF005F	No listeners condition was detected.
BFFF0060	This interface is not the controller in charge.
BFFF0067	Operation is not supported on this session.



PM1313B_PWR_DIAGDPRTTEST

```
ViStatus PM1313B_pwr_DiagDprTest (ViSession instrumentHandle);
```

PURPOSE

This function performs a Dual-Port RAM test.

PARAMETER LIST

instrumentHandle

Variable Type: **ViSession**

This control returns an **InstrumentHandle** that is used in all subsequent function calls to differentiate between different sessions of the instrument driver.

NOTE

Each time this function is invoked, a unique session is opened. It is possible to have more than one session open for the same resource.

RETURN VALUE

This control contains the status code returned by the function call.

Status Codes:

<u>Status</u>	<u>Description</u>
0	No error (the call was successful).
3FFC0101	ID Query not supported - VI_WARN_NSUP_ID_QUERY
3FFC0102	Reset not supported - VI_WARN_NSUP_RESET
3FFC0103	Self Test not supported - VI_WARN_NSUP_SELF_TEST
3FFC0104	Error Query not supported - VI_WARN_NSUP_ERROR_QUERY
3FFC0105	Revision Query not supported - VI_WARN_NSUP_REV_QUERY
3FFF0005	The specified termination character was read.
3FFF0006	The specified number of bytes was read.
BFFC0001	Parameter 1 out of range. (String not range checked)
BFFC0002	Parameter 2 (ID Query) out of range.
BFFC0003	Parameter 3 (Reset Device) out of range.
BFFC0004	Parameter 4 out of range.
BFFC0005	Parameter 5 out of range.
BFFC0006	Parameter 6 out of range.



BFFC0007	Parameter 7 out of range.
BFFC0008	Parameter 8 out of range.
BFFC0011	Instrument returned invalid response to ID Query
BFFC0800	Error Opening File VI_ERROR_INSTR_FILE_OPEN
BFFC0801	Error Writing to File VI_ERROR_INSTR_FILE_WRITE
BFFC0803	Invalid Response VI_ERROR_INSTR_INTERPRETING_RESPONSE
BFFC0809	Parameter 9 out of range. VI_ERROR_INSTR_PARAMETER9
BFFC080A	Parameter 10 out of range. VI_ERROR_INSTR_PARAMETER10
BFFC080B	Parameter 11 out of range. VI_ERROR_INSTR_PARAMETER11
BFFC080C	Parameter 12 out of range. VI_ERROR_INSTR_PARAMETER12
BFFF0000	Miscellaneous or system error occurred.
BFFF000E	Invalid session handle.
BFFF0015	Timeout occurred before operation could complete.
BFFF0034	Violation of raw write protocol occurred.
BFFF0035	Violation of raw read protocol occurred.
BFFF0036	Device reported an output protocol error.
BFFF0037	Device reported an input protocol error.
BFFF0038	Bus error occurred during transfer.
BFFF003A	Invalid setup (attributes are not consistent).
BFFF005F	No listeners condition was detected.
BFFF0060	This interface is not the controller in charge.
BFFF0067	Operation is not supported on this session.



PM1313B_PWR_INIT

```
ViStatus PM1313B_pwr_init (ViSession instrumentHandle);
```

PURPOSE

This function initializes the power meter. It is required in order to allow **pm_task** to run.

PARAMETER LIST

instrumentHandle

Variable Type: **ViSession**

This control returns an **InstrumentHandle** that is used in all subsequent function calls to differentiate between different sessions of the instrument driver.

NOTE

Each time this function is invoked, a unique session is opened. It is possible to have more than one session open for the same resource.

RETURN VALUE

This control contains the status code returned by the function call.

Status Codes:

<u>Status</u>	<u>Description</u>
0	No error (the call was successful).
3FFC0101	ID Query not supported - VI_WARN_NSUP_ID_QUERY
3FFC0102	Reset not supported - VI_WARN_NSUP_RESET
3FFC0103	Self Test not supported - VI_WARN_NSUP_SELF_TEST
3FFC0104	Error Query not supported - VI_WARN_NSUP_ERROR_QUERY
3FFC0105	Revision Query not supported - VI_WARN_NSUP_REV_QUERY
3FFF0005	The specified termination character was read.
3FFF0006	The specified number of bytes was read.
BFFC0001	Parameter 1 out of range. (String not range checked)
BFFC0002	Parameter 2 (ID Query) out of range.
BFFC0003	Parameter 3 (Reset Device) out of range.
BFFC0004	Parameter 4 out of range.
BFFC0005	Parameter 5 out of range.
BFFC0006	Parameter 6 out of range.



BFFC0007	Parameter 7 out of range.
BFFC0008	Parameter 8 out of range.
BFFC0011	Instrument returned invalid response to ID Query
BFFC0800	Error Opening File VI_ERROR_INSTR_FILE_OPEN
BFFC0801	Error Writing to File VI_ERROR_INSTR_FILE_WRITE
BFFC0803	Invalid Response VI_ERROR_INSTR_INTERPRETING_RESPONSE
BFFC0809	Parameter 9 out of range. VI_ERROR_INSTR_PARAMETER9
BFFC080A	Parameter 10 out of range. VI_ERROR_INSTR_PARAMETER10
BFFC080B	Parameter 11 out of range. VI_ERROR_INSTR_PARAMETER11
BFFC080C	Parameter 12 out of range. VI_ERROR_INSTR_PARAMETER12
BFFF0000	Miscellaneous or system error occurred.
BFFF000E	Invalid session handle.
BFFF0015	Timeout occurred before operation could complete.
BFFF0034	Violation of raw write protocol occurred.
BFFF0035	Violation of raw read protocol occurred.
BFFF0036	Device reported an output protocol error.
BFFF0037	Device reported an input protocol error.
BFFF0038	Bus error occurred during transfer.
BFFF003A	Invalid setup (attributes are not consistent).
BFFF005F	No listeners condition was detected.
BFFF0060	This interface is not the controller in charge.
BFFF0067	Operation is not supported on this session.



PM1313B_PWR_MSG_RECEIVE

```
ViStatus PM1313B_pwr_msg_receive (ViSession instrumentHandle);
```

PURPOSE

This function is utilized to check whether or not a message is available from the power meter.

PARAMETER LIST

instrumentHandle

Variable Type: ViSession

This control returns an **InstrumentHandle** that is used in all subsequent function calls to differentiate between different sessions of the instrument driver.

NOTE

Each time this function is invoked, a unique session is opened. It is possible to have more than one session open for the same resource.

RETURN VALUE

This control contains the status code returned by the function call.

Status Codes:

<u>Status</u>	<u>Description</u>
0	No error (the call was successful).
3FFC0101	ID Query not supported - VI_WARN_NSUP_ID_QUERY
3FFC0102	Reset not supported - VI_WARN_NSUP_RESET
3FFC0103	Self Test not supported - VI_WARN_NSUP_SELF_TEST
3FFC0104	Error Query not supported - VI_WARN_NSUP_ERROR_QUERY
3FFC0105	Revision Query not supported - VI_WARN_NSUP_REV_QUERY
3FFF0005	The specified termination character was read.
3FFF0006	The specified number of bytes was read.
BFFC0001	Parameter 1 out of range. (String not range checked)
BFFC0002	Parameter 2 (ID Query) out of range.
BFFC0003	Parameter 3 (Reset Device) out of range.
BFFC0004	Parameter 4 out of range.
BFFC0005	Parameter 5 out of range.
BFFC0006	Parameter 6 out of range.



BFFC0007	Parameter 7 out of range.
BFFC0008	Parameter 8 out of range.
BFFC0011	Instrument returned invalid response to ID Query
BFFC0800	Error Opening File VI_ERROR_INSTR_FILE_OPEN
BFFC0801	Error Writing to File VI_ERROR_INSTR_FILE_WRITE
BFFC0803	Invalid Response VI_ERROR_INSTR_INTERPRETING_RESPONSE
BFFC0809	Parameter 9 out of range. VI_ERROR_INSTR_PARAMETER9
BFFC080A	Parameter 10 out of range. VI_ERROR_INSTR_PARAMETER10
BFFC080B	Parameter 11 out of range. VI_ERROR_INSTR_PARAMETER11
BFFC080C	Parameter 12 out of range. VI_ERROR_INSTR_PARAMETER12
BFFF0000	Miscellaneous or system error occurred.
BFFF000E	Invalid session handle.
BFFF0015	Timeout occurred before operation could complete.
BFFF0034	Violation of raw write protocol occurred.
BFFF0035	Violation of raw read protocol occurred.
BFFF0036	Device reported an output protocol error.
BFFF0037	Device reported an input protocol error.
BFFF0038	Bus error occurred during transfer.
BFFF003A	Invalid setup (attributes are not consistent).
BFFF005F	No listeners condition was detected.
BFFF0060	This interface is not the controller in charge.
BFFF0067	Operation is not supported on this session.



PM1313B_PWR_MSGPROC

```
ViStatus PM1313B_pwr_MsgProc (ViSession instrumentHandle);
```

PURPOSE

This function queries processes messages that have been placed in **PmReplyMsg** from the power meter.

PARAMETER LIST

instrumentHandle

Variable Type: **ViSession**

This control returns an **InstrumentHandle** that is used in all subsequent function calls to differentiate between different sessions of the instrument driver.

NOTE

Each time this function is invoked, a unique session is opened. It is possible to have more than one session open for the same resource.

RETURN VALUE

This control contains the status code returned by the function call.

Status Codes:

<u>Status</u>	<u>Description</u>
0	No error (the call was successful).
3FFC0101	ID Query not supported - VI_WARN_NSUP_ID_QUERY
3FFC0102	Reset not supported - VI_WARN_NSUP_RESET
3FFC0103	Self Test not supported - VI_WARN_NSUP_SELF_TEST
3FFC0104	Error Query not supported - VI_WARN_NSUP_ERROR_QUERY
3FFC0105	Revision Query not supported - VI_WARN_NSUP_REV_QUERY
3FFF0005	The specified termination character was read.
3FFF0006	The specified number of bytes was read.
BFFC0001	Parameter 1 out of range. (String not range checked)
BFFC0002	Parameter 2 (ID Query) out of range.
BFFC0003	Parameter 3 (Reset Device) out of range.
BFFC0004	Parameter 4 out of range.
BFFC0005	Parameter 5 out of range.



BFFC0006	Parameter 6 out of range.
BFFC0007	Parameter 7 out of range.
BFFC0008	Parameter 8 out of range.
BFFC0011	Instrument returned invalid response to ID Query
BFFC0800	Error Opening File VI_ERROR_INSTR_FILE_OPEN
BFFC0801	Error Writing to File VI_ERROR_INSTR_FILE_WRITE
BFFC0803	Invalid Response VI_ERROR_INSTR_INTERPRETING_RESPONSE
BFFC0809	Parameter 9 out of range. VI_ERROR_INSTR_PARAMETER9
BFFC080A	Parameter 10 out of range. VI_ERROR_INSTR_PARAMETER10
BFFC080B	Parameter 11 out of range. VI_ERROR_INSTR_PARAMETER11
BFFC080C	Parameter 12 out of range. VI_ERROR_INSTR_PARAMETER12
BFFF0000	Miscellaneous or system error occurred.
BFFF000E	Invalid session handle.
BFFF0015	Timeout occurred before operation could complete.
BFFF0034	Violation of raw write protocol occurred.
BFFF0035	Violation of raw read protocol occurred.
BFFF0036	Device reported an output protocol error.
BFFF0037	Device reported an input protocol error.
BFFF0038	Bus error occurred during transfer.
BFFF003A	Invalid setup (attributes are not consistent).
BFFF005F	No listeners condition was detected.
BFFF0060	This interface is not the controller in charge.
BFFF0067	Operation is not supported on this session.



PM1313B_PWR_MSGSEND

```
ViStatus PM1313B_pwr_MsgSend (ViSession instrumentHandle);
```

PURPOSE

This function can be utilized to send a message to the power meter.

PARAMETER LIST

instrumentHandle

Variable Type: **ViSession**

This control returns an **InstrumentHandle** that is used in all subsequent function calls to differentiate between different sessions of the instrument driver.

NOTE

Each time this function is invoked, a unique session is opened. It is possible to have more than one session open for the same resource.

RETURN VALUE

This control contains the status code returned by the function call.

Status Codes:

<u>Status</u>	<u>Description</u>
0	No error (the call was successful).
3FFC0101	ID Query not supported - VI_WARN_NSUP_ID_QUERY
3FFC0102	Reset not supported - VI_WARN_NSUP_RESET
3FFC0103	Self Test not supported - VI_WARN_NSUP_SELF_TEST
3FFC0104	Error Query not supported - VI_WARN_NSUP_ERROR_QUERY
3FFC0105	Revision Query not supported - VI_WARN_NSUP_REV_QUERY
3FFF0005	The specified termination character was read.
3FFF0006	The specified number of bytes was read.
BFFC0001	Parameter 1 out of range. (String not range checked)
BFFC0002	Parameter 2 (ID Query) out of range.
BFFC0003	Parameter 3 (Reset Device) out of range.
BFFC0004	Parameter 4 out of range.
BFFC0005	Parameter 5 out of range.
BFFC0006	Parameter 6 out of range.



BFFC0007	Parameter 7 out of range.
BFFC0008	Parameter 8 out of range.
BFFC0011	Instrument returned invalid response to ID Query
BFFC0800	Error Opening File VI_ERROR_INSTR_FILE_OPEN
BFFC0801	Error Writing to File VI_ERROR_INSTR_FILE_WRITE
BFFC0803	Invalid Response VI_ERROR_INSTR_INTERPRETING_RESPONSE
BFFC0809	Parameter 9 out of range. VI_ERROR_INSTR_PARAMETER9
BFFC080A	Parameter 10 out of range. VI_ERROR_INSTR_PARAMETER10
BFFC080B	Parameter 11 out of range. VI_ERROR_INSTR_PARAMETER11
BFFC080C	Parameter 12 out of range. VI_ERROR_INSTR_PARAMETER12
BFFF0000	Miscellaneous or system error occurred.
BFFF000E	Invalid session handle.
BFFF0015	Timeout occurred before operation could complete.
BFFF0034	Violation of raw write protocol occurred.
BFFF0035	Violation of raw read protocol occurred.
BFFF0036	Device reported an output protocol error.
BFFF0037	Device reported an input protocol error.
BFFF0038	Bus error occurred during transfer.
BFFF003A	Invalid setup (attributes are not consistent).
BFFF005F	No listeners condition was detected.
BFFF0060	This interface is not the controller in charge.
BFFF0067	Operation is not supported on this session.



PM1313B_PWR_OFF

```
ViStatus PM1313B_pwr_Off (ViSession instrumentHandle);
```

PURPOSE

This function turns off the power meter section.

PARAMETER LIST

instrumentHandle

Variable Type: **ViSession**

This control returns an **InstrumentHandle** that is used in all subsequent function calls to differentiate between different sessions of the instrument driver.

NOTE

Each time this function is invoked, a unique session is opened. It is possible to have more than one session open for the same resource.

RETURN VALUE

This control contains the status code returned by the function call.

Status Codes:

<u>Status</u>	<u>Description</u>
0	No error (the call was successful).
3FFC0101	ID Query not supported - VI_WARN_NSUP_ID_QUERY
3FFC0102	Reset not supported - VI_WARN_NSUP_RESET
3FFC0103	Self Test not supported - VI_WARN_NSUP_SELF_TEST
3FFC0104	Error Query not supported - VI_WARN_NSUP_ERROR_QUERY
3FFC0105	Revision Query not supported - VI_WARN_NSUP_REV_QUERY
3FFF0005	The specified termination character was read.
3FFF0006	The specified number of bytes was read.
BFFC0001	Parameter 1 out of range. (String not range checked)
BFFC0002	Parameter 2 (ID Query) out of range.
BFFC0003	Parameter 3 (Reset Device) out of range.
BFFC0004	Parameter 4 out of range.
BFFC0005	Parameter 5 out of range.
BFFC0006	Parameter 6 out of range.



BFFC0007	Parameter 7 out of range.
BFFC0008	Parameter 8 out of range.
BFFC0011	Instrument returned invalid response to ID Query
BFFC0800	Error Opening File VI_ERROR_INSTR_FILE_OPEN
BFFC0801	Error Writing to File VI_ERROR_INSTR_FILE_WRITE
BFFC0803	Invalid Response VI_ERROR_INSTR_INTERPRETING_RESPONSE
BFFC0809	Parameter 9 out of range. VI_ERROR_INSTR_PARAMETER9
BFFC080A	Parameter 10 out of range. VI_ERROR_INSTR_PARAMETER10
BFFC080B	Parameter 11 out of range. VI_ERROR_INSTR_PARAMETER11
BFFC080C	Parameter 12 out of range. VI_ERROR_INSTR_PARAMETER12
BFFF0000	Miscellaneous or system error occurred.
BFFF000E	Invalid session handle.
BFFF0015	Timeout occurred before operation could complete.
BFFF0034	Violation of raw write protocol occurred.
BFFF0035	Violation of raw read protocol occurred.
BFFF0036	Device reported an output protocol error.
BFFF0037	Device reported an input protocol error.
BFFF0038	Bus error occurred during transfer.
BFFF003A	Invalid setup (attributes are not consistent).
BFFF005F	No listeners condition was detected.
BFFF0060	This interface is not the controller in charge.
BFFF0067	Operation is not supported on this session.



PM1313B_PWR_POST

```
ViStatus PM1313B_pwr_post (ViSession instrumentHandle);
```

PURPOSE

This function performs power meter Power-On-Self-Test, which relates to the power-up sequence.

PARAMETER LIST

instrumentHandle

Variable Type: **ViSession**

This control returns an **InstrumentHandle** that is used in all subsequent function calls to differentiate between different sessions of the instrument driver.

NOTE

Each time this function is invoked, a unique session is opened. It is possible to have more than one session open for the same resource.

RETURN VALUE

This control contains the status code returned by the function call.

Status Codes:

<u>Status</u>	<u>Description</u>
0	No error (the call was successful).
3FFC0101	ID Query not supported - VI_WARN_NSUP_ID_QUERY
3FFC0102	Reset not supported - VI_WARN_NSUP_RESET
3FFC0103	Self Test not supported - VI_WARN_NSUP_SELF_TEST
3FFC0104	Error Query not supported - VI_WARN_NSUP_ERROR_QUERY
3FFC0105	Revision Query not supported - VI_WARN_NSUP_REV_QUERY
3FFF0005	The specified termination character was read.
3FFF0006	The specified number of bytes was read.
BFFC0001	Parameter 1 out of range. (String not range checked)
BFFC0002	Parameter 2 (ID Query) out of range.
BFFC0003	Parameter 3 (Reset Device) out of range.
BFFC0004	Parameter 4 out of range.
BFFC0005	Parameter 5 out of range.



BFFC0006	Parameter 6 out of range.
BFFC0007	Parameter 7 out of range.
BFFC0008	Parameter 8 out of range.
BFFC0011	Instrument returned invalid response to ID Query
BFFC0800	Error Opening File VI_ERROR_INSTR_FILE_OPEN
BFFC0801	Error Writing to File VI_ERROR_INSTR_FILE_WRITE
BFFC0803	Invalid Response VI_ERROR_INSTR_INTERPRETING_RESPONSE
BFFC0809	Parameter 9 out of range. VI_ERROR_INSTR_PARAMETER9
BFFC080A	Parameter 10 out of range. VI_ERROR_INSTR_PARAMETER10
BFFC080B	Parameter 11 out of range. VI_ERROR_INSTR_PARAMETER11
BFFC080C	Parameter 12 out of range. VI_ERROR_INSTR_PARAMETER12
BFFF0000	Miscellaneous or system error occurred.
BFFF000E	Invalid session handle.
BFFF0015	Timeout occurred before operation could complete.
BFFF0034	Violation of raw write protocol occurred.
BFFF0035	Violation of raw read protocol occurred.
BFFF0036	Device reported an output protocol error.
BFFF0037	Device reported an input protocol error.
BFFF0038	Bus error occurred during transfer.
BFFF003A	Invalid setup (attributes are not consistent).
BFFF005F	No listeners condition was detected.
BFFF0060	This interface is not the controller in charge.
BFFF0067	Operation is not supported on this session.



PM1313B_PWR_PRESET

```
ViStatus PM1313B_pwr_preset (ViSession instrumentHandle);
```

PURPOSE

This function presets the power meter through the following internal functions:

1. Cal factors are set to default.
2. Ref Osc is turned Off.
3. Units are set to dBm.
4. Trigger mode set to Free Run.
5. Auto Range is turned ON.
6. CAL and ZERO data are retained.

PARAMETER LIST

instrumentHandle

Variable Type: **ViSession**

This control returns an **InstrumentHandle** that is used in all subsequent function calls to differentiate between different sessions of the instrument driver.

NOTE

Each time this function is invoked, a unique session is opened. It is possible to have more than one session open for the same resource.

RETURN VALUE

This control contains the status code returned by the function call.

Status Codes:

<u>Status</u>	<u>Description</u>
0	No error (the call was successful).
3FFC0101	ID Query not supported - VI_WARN_NSUP_ID_QUERY
3FFC0102	Reset not supported - VI_WARN_NSUP_RESET
3FFC0103	Self Test not supported - VI_WARN_NSUP_SELF_TEST



3FFC0104	Error Query not supported - VI_WARN_NSUP_ERROR_QUERY
3FFC0105	Revision Query not supported - VI_WARN_NSUP_REV_QUERY
3FFF0005	The specified termination character was read.
3FFF0006	The specified number of bytes was read.
BFFC0001	Parameter 1 out of range. (String not range checked)
BFFC0002	Parameter 2 (ID Query) out of range.
BFFC0003	Parameter 3 (Reset Device) out of range.
BFFC0004	Parameter 4 out of range.
BFFC0005	Parameter 5 out of range.
BFFC0006	Parameter 6 out of range.
BFFC0007	Parameter 7 out of range.
BFFC0008	Parameter 8 out of range.
BFFC0011	Instrument returned invalid response to ID Query
BFFC0800	Error Opening File VI_ERROR_INSTR_FILE_OPEN
BFFC0801	Error Writing to File VI_ERROR_INSTR_FILE_WRITE
BFFC0803	Invalid Response VI_ERROR_INSTR_INTERPRETING_RESPONSE
BFFC0809	Parameter 9 out of range. VI_ERROR_INSTR_PARAMETER9
BFFC080A	Parameter 10 out of range. VI_ERROR_INSTR_PARAMETER10
BFFC080B	Parameter 11 out of range. VI_ERROR_INSTR_PARAMETER11
BFFC080C	Parameter 12 out of range. VI_ERROR_INSTR_PARAMETER12
BFFF0000	Miscellaneous or system error occurred.
BFFF000E	Invalid session handle.
BFFF0015	Timeout occurred before operation could complete.
BFFF0034	Violation of raw write protocol occurred.
BFFF0035	Violation of raw read protocol occurred.
BFFF0036	Device reported an output protocol error.
BFFF0037	Device reported an input protocol error.
BFFF0038	Bus error occurred during transfer.
BFFF003A	Invalid setup (attributes are not consistent).
BFFF005F	No listeners condition was detected.
BFFF0060	This interface is not the controller in charge.
BFFF0067	Operation is not supported on this session.



PM1313B_PWR_RANGE

ViStatus PM1313B_pwr_range (ViSession instrumentHandle, short range);

PURPOSE

This function sets the power range to manual or auto.

0 = Auto

1 - 5 = Valid ranges 10 dB apart

PARAMETER LIST

instrumentHandle

Variable Type: **ViSession**

This control returns an **InstrumentHandle** that is used in all subsequent function calls to differentiate between different sessions of the instrument driver.

NOTE

Each time this function is invoked, a unique session is opened. It is possible to have more than one session open for the same resource.

range

Variable Type: short

RETURN VALUE

This control contains the status code returned by the function call.

Status Codes:

<u>Status</u>	<u>Description</u>
0	No error (the call was successful).
3FFC0101	ID Query not supported - VI_WARN_NSUP_ID_QUERY
3FFC0102	Reset not supported - VI_WARN_NSUP_RESET
3FFC0103	Self Test not supported - VI_WARN_NSUP_SELF_TEST
3FFC0104	Error Query not supported - VI_WARN_NSUP_ERROR_QUERY
3FFC0105	Revision Query not supported - VI_WARN_NSUP_REV_QUERY
3FFF0005	The specified termination character was read.
3FFF0006	The specified number of bytes was read.



BFFC0001	Parameter 1 out of range. (String not range checked)
BFFC0002	Parameter 2 (ID Query) out of range.
BFFC0003	Parameter 3 (Reset Device) out of range.
BFFC0004	Parameter 4 out of range.
BFFC0005	Parameter 5 out of range.
BFFC0006	Parameter 6 out of range.
BFFC0007	Parameter 7 out of range.
BFFC0008	Parameter 8 out of range.
BFFC0011	Instrument returned invalid response to ID Query
BFFC0800	Error Opening File VI_ERROR_INSTR_FILE_OPEN
BFFC0801	Error Writing to File VI_ERROR_INSTR_FILE_WRITE
BFFC0803	Invalid Response VI_ERROR_INSTR_INTERPRETING_RESPONSE
BFFC0809	Parameter 9 out of range. VI_ERROR_INSTR_PARAMETER9
BFFC080A	Parameter 10 out of range. VI_ERROR_INSTR_PARAMETER10
BFFC080B	Parameter 11 out of range. VI_ERROR_INSTR_PARAMETER11
BFFC080C	Parameter 12 out of range. VI_ERROR_INSTR_PARAMETER12
BFFF0000	Miscellaneous or system error occurred.
BFFF000E	Invalid session handle.
BFFF0015	Timeout occurred before operation could complete.
BFFF0034	Violation of raw write protocol occurred.
BFFF0035	Violation of raw read protocol occurred.
BFFF0036	Device reported an output protocol error.
BFFF0037	Device reported an input protocol error.
BFFF0038	Bus error occurred during transfer.
BFFF003A	Invalid setup (attributes are not consistent).
BFFF005F	No listeners condition was detected.
BFFF0060	This interface is not the controller in charge.
BFFF0067	Operation is not supported on this session.



PM1313B_PWR_REFOSC_OFF

```
ViStatus PM1313B_pwr_refosc_off (ViSession instrumentHandle);
```

PURPOSE

This function turns OFF the power meter reference for sensor calibration.

PARAMETER LIST

instrumentHandle

Variable Type: **ViSession**

This control returns an **InstrumentHandle** that is used in all subsequent function calls to differentiate between different sessions of the instrument driver.

NOTE

Each time this function is invoked, a unique session is opened. It is possible to have more than one session open for the same resource.

RETURN VALUE

This control contains the status code returned by the function call.

Status Codes:

<u>Status</u>	<u>Description</u>
0	No error (the call was successful).
3FFC0101	ID Query not supported - VI_WARN_NSUP_ID_QUERY
3FFC0102	Reset not supported - VI_WARN_NSUP_RESET
3FFC0103	Self Test not supported - VI_WARN_NSUP_SELF_TEST
3FFC0104	Error Query not supported - VI_WARN_NSUP_ERROR_QUERY
3FFC0105	Revision Query not supported - VI_WARN_NSUP_REV_QUERY
3FFF0005	The specified termination character was read.
3FFF0006	The specified number of bytes was read.
BFFC0001	Parameter 1 out of range. (String not range checked)
BFFC0002	Parameter 2 (ID Query) out of range.
BFFC0003	Parameter 3 (Reset Device) out of range.
BFFC0004	Parameter 4 out of range.
BFFC0005	Parameter 5 out of range.
BFFC0006	Parameter 6 out of range.



BFFC0007	Parameter 7 out of range.
BFFC0008	Parameter 8 out of range.
BFFC0011	Instrument returned invalid response to ID Query
BFFC0800	Error Opening File VI_ERROR_INSTR_FILE_OPEN
BFFC0801	Error Writing to File VI_ERROR_INSTR_FILE_WRITE
BFFC0803	Invalid Response VI_ERROR_INSTR_INTERPRETING_RESPONSE
BFFC0809	Parameter 9 out of range. VI_ERROR_INSTR_PARAMETER9
BFFC080A	Parameter 10 out of range. VI_ERROR_INSTR_PARAMETER10
BFFC080B	Parameter 11 out of range. VI_ERROR_INSTR_PARAMETER11
BFFC080C	Parameter 12 out of range. VI_ERROR_INSTR_PARAMETER12
BFFF0000	Miscellaneous or system error occurred.
BFFF000E	Invalid session handle.
BFFF0015	Timeout occurred before operation could complete.
BFFF0034	Violation of raw write protocol occurred.
BFFF0035	Violation of raw read protocol occurred.
BFFF0036	Device reported an output protocol error.
BFFF0037	Device reported an input protocol error.
BFFF0038	Bus error occurred during transfer.
BFFF003A	Invalid setup (attributes are not consistent).
BFFF005F	No listeners condition was detected.
BFFF0060	This interface is not the controller in charge.
BFFF0067	Operation is not supported on this session.



PM1313B_PWR_REFOSC_ON

```
ViStatus PM1313B_pwr_refosc_on (ViSession instrumentHandle);
```

PURPOSE

This function turns ON the power meter reference for sensor calibration.

PARAMETER LIST

instrumentHandle

Variable Type: **ViSession**

This control returns an **InstrumentHandle** that is used in all subsequent function calls to differentiate between different sessions of the instrument driver.

NOTE

Each time this function is invoked, a unique session is opened. It is possible to have more than one session open for the same resource.

RETURN VALUE

This control contains the status code returned by the function call.

Status Codes:

<u>Status</u>	<u>Description</u>
0	No error (the call was successful).
3FFC0101	ID Query not supported - VI_WARN_NSUP_ID_QUERY
3FFC0102	Reset not supported - VI_WARN_NSUP_RESET
3FFC0103	Self Test not supported - VI_WARN_NSUP_SELF_TEST
3FFC0104	Error Query not supported - VI_WARN_NSUP_ERROR_QUERY
3FFC0105	Revision Query not supported - VI_WARN_NSUP_REV_QUERY
3FFF0005	The specified termination character was read.
3FFF0006	The specified number of bytes was read.
BFFC0001	Parameter 1 out of range. (String not range checked)
BFFC0002	Parameter 2 (ID Query) out of range.
BFFC0003	Parameter 3 (Reset Device) out of range.
BFFC0004	Parameter 4 out of range.
BFFC0005	Parameter 5 out of range.
BFFC0006	Parameter 6 out of range.



BFFC0007	Parameter 7 out of range.
BFFC0008	Parameter 8 out of range.
BFFC0011	Instrument returned invalid response to ID Query
BFFC0800	Error Opening File VI_ERROR_INSTR_FILE_OPEN
BFFC0801	Error Writing to File VI_ERROR_INSTR_FILE_WRITE
BFFC0803	Invalid Response VI_ERROR_INSTR_INTERPRETING_RESPONSE
BFFC0809	Parameter 9 out of range. VI_ERROR_INSTR_PARAMETER9
BFFC080A	Parameter 10 out of range. VI_ERROR_INSTR_PARAMETER10
BFFC080B	Parameter 11 out of range. VI_ERROR_INSTR_PARAMETER11
BFFC080C	Parameter 12 out of range. VI_ERROR_INSTR_PARAMETER12
BFFF0000	Miscellaneous or system error occurred.
BFFF000E	Invalid session handle.
BFFF0015	Timeout occurred before operation could complete.
BFFF0034	Violation of raw write protocol occurred.
BFFF0035	Violation of raw read protocol occurred.
BFFF0036	Device reported an output protocol error.
BFFF0037	Device reported an input protocol error.
BFFF0038	Bus error occurred during transfer.
BFFF003A	Invalid setup (attributes are not consistent).
BFFF005F	No listeners condition was detected.
BFFF0060	This interface is not the controller in charge.
BFFF0067	Operation is not supported on this session.



PM1313B_PWR_RESET

```
ViStatus PM1313B_pwr_reset (ViSession instrumentHandle);
```

PURPOSE

This function resets the power meter through the following internal funtions:

1. The Power-Up state is set.
2. Trigger mode set to Free Run.
3. Auto Range is turned ON.
4. CAL and ZERO data are purged.

PARAMETER LIST

instrumentHandle

Variable Type: **ViSESSION**

This control returns an **InstrumentHandle** that is used in all subsequent function calls to differentiate between different sessions of the instrument driver.

NOTE

Each time this function is invoked, a unique session is opened. It is possible to have more than one session open for the same resource.

RETURN VALUE

This control contains the status code returned by the function call.

Status Codes:

<u>Status</u>	<u>Description</u>
0	No error (the call was successful).
3FFC0101	ID Query not supported - VI_WARN_NSUP_ID_QUERY
3FFC0102	Reset not supported - VI_WARN_NSUP_RESET
3FFC0103	Self Test not supported - VI_WARN_NSUP_SELF_TEST
3FFC0104	Error Query not supported - VI_WARN_NSUP_ERROR_QUERY
3FFC0105	Revision Query not supported - VI_WARN_NSUP_REV_QUERY
3FFF0005	The specified termination character was read.



3FFF0006	The specified number of bytes was read.
BFFC0001	Parameter 1 out of range. (String not range checked)
BFFC0002	Parameter 2 (ID Query) out of range.
BFFC0003	Parameter 3 (Reset Device) out of range.
BFFC0004	Parameter 4 out of range.
BFFC0005	Parameter 5 out of range.
BFFC0006	Parameter 6 out of range.
BFFC0007	Parameter 7 out of range.
BFFC0008	Parameter 8 out of range.
BFFC0011	Instrument returned invalid response to ID Query
BFFC0800	Error Opening File VI_ERROR_INSTR_FILE_OPEN
BFFC0801	Error Writing to File VI_ERROR_INSTR_FILE_WRITE
BFFC0803	Invalid Response VI_ERROR_INSTR_INTERPRETING_RESPONSE
BFFC0809	Parameter 9 out of range. VI_ERROR_INSTR_PARAMETER9
BFFC080A	Parameter 10 out of range. VI_ERROR_INSTR_PARAMETER10
BFFC080B	Parameter 11 out of range. VI_ERROR_INSTR_PARAMETER11
BFFC080C	Parameter 12 out of range. VI_ERROR_INSTR_PARAMETER12
BFFF0000	Miscellaneous or system error occurred.
BFFF000E	Invalid session handle.
BFFF0015	Timeout occurred before operation could complete.
BFFF0034	Violation of raw write protocol occurred.
BFFF0035	Violation of raw read protocol occurred.
BFFF0036	Device reported an output protocol error.
BFFF0037	Device reported an input protocol error.
BFFF0038	Bus error occurred during transfer.
BFFF003A	Invalid setup (attributes are not consistent).
BFFF005F	No listeners condition was detected.
BFFF0060	This interface is not the controller in charge.
BFFF0067	Operation is not supported on this session.



PM1313B_PWR_SELF_TEST

```
ViStatus PM1313B_pwr_self_test (ViSession instrumentHandle);
```

PURPOSE

This function instructs the power meter to perform a self-test.

PARAMETER LIST

instrumentHandle

Variable Type: **ViSession**

This control returns an **InstrumentHandle** that is used in all subsequent function calls to differentiate between different sessions of the instrument driver.

NOTE

Each time this function is invoked, a unique session is opened. It is possible to have more than one session open for the same resource.

RETURN VALUE

This control contains the status code returned by the function call.

Status Codes:

<u>Status</u>	<u>Description</u>
0	No error (the call was successful).
3FFC0101	ID Query not supported - VI_WARN_NSUP_ID_QUERY
3FFC0102	Reset not supported - VI_WARN_NSUP_RESET
3FFC0103	Self Test not supported - VI_WARN_NSUP_SELF_TEST
3FFC0104	Error Query not supported - VI_WARN_NSUP_ERROR_QUERY
3FFC0105	Revision Query not supported - VI_WARN_NSUP_REV_QUERY
3FFF0005	The specified termination character was read.
3FFF0006	The specified number of bytes was read.
BFFC0001	Parameter 1 out of range. (String not range checked)
BFFC0002	Parameter 2 (ID Query) out of range.
BFFC0003	Parameter 3 (Reset Device) out of range.
BFFC0004	Parameter 4 out of range.
BFFC0005	Parameter 5 out of range.
BFFC0006	Parameter 6 out of range.



BFFC0007	Parameter 7 out of range.
BFFC0008	Parameter 8 out of range.
BFFC0011	Instrument returned invalid response to ID Query
BFFC0800	Error Opening File VI_ERROR_INSTR_FILE_OPEN
BFFC0801	Error Writing to File VI_ERROR_INSTR_FILE_WRITE
BFFC0803	Invalid Response VI_ERROR_INSTR_INTERPRETING_RESPONSE
BFFC0809	Parameter 9 out of range. VI_ERROR_INSTR_PARAMETER9
BFFC080A	Parameter 10 out of range. VI_ERROR_INSTR_PARAMETER10
BFFC080B	Parameter 11 out of range. VI_ERROR_INSTR_PARAMETER11
BFFC080C	Parameter 12 out of range. VI_ERROR_INSTR_PARAMETER12
BFFF0000	Miscellaneous or system error occurred.
BFFF000E	Invalid session handle.
BFFF0015	Timeout occurred before operation could complete.
BFFF0034	Violation of raw write protocol occurred.
BFFF0035	Violation of raw read protocol occurred.
BFFF0036	Device reported an output protocol error.
BFFF0037	Device reported an input protocol error.
BFFF0038	Bus error occurred during transfer.
BFFF003A	Invalid setup (attributes are not consistent).
BFFF005F	No listeners condition was detected.
BFFF0060	This interface is not the controller in charge.
BFFF0067	Operation is not supported on this session.



PM1313B_PWR_STATUS_AND_ERRORS

```
ViStatus PM1313B_pwr_Status_and_Errors (ViSession instrumentHandle, ViChar  
_VI_FAR pwrErrors[], ViChar _VI_FAR pwrMeterStatus[], unsigned long *outCode);
```

PURPOSE

This function is used in conjunction with **Pwr_Initialize** to perform check on power meter status and error conditions.

PARAMETER LIST

instrumentHandle

Variable Type: **ViSession**

This control returns an **InstrumentHandle** that is used in all subsequent function calls to differentiate between different sessions of the instrument driver.

NOTE

Each time this function is invoked, a unique session is opened. It is possible to have more than one session open for the same resource.

pwrErrors

Variable Type: **ViChar[]**

This indicator shows power meter errors.

pwrMeterStatus

Variable Type: **ViChar[]**

This indicator shows power meter status and errors

outCode

Variable Type: unsigned long (passed by reference)

This indicator shows numerical code related to power meter status and errors.

RETURN VALUE

This control contains the status code returned by the function call.

Status Codes:



<u>Status</u>	<u>Description</u>
0	No error (the call was successful).
3FFC0101	ID Query not supported - VI_WARN_NSUP_ID_QUERY
3FFC0102	Reset not supported - VI_WARN_NSUP_RESET
3FFC0103	Self Test not supported - VI_WARN_NSUP_SELF_TEST
3FFC0104	Error Query not supported - VI_WARN_NSUP_ERROR_QUERY
3FFC0105	Revision Query not supported - VI_WARN_NSUP_REV_QUERY
3FFF0005	The specified termination character was read.
3FFF0006	The specified number of bytes was read.
BFFC0001	Parameter 1 out of range. (String not range checked)
BFFC0002	Parameter 2 (ID Query) out of range.
BFFC0003	Parameter 3 (Reset Device) out of range.
BFFC0004	Parameter 4 out of range.
BFFC0005	Parameter 5 out of range.
BFFC0006	Parameter 6 out of range.
BFFC0007	Parameter 7 out of range.
BFFC0008	Parameter 8 out of range.
BFFC0011	Instrument returned invalid response to ID Query
BFFC0800	Error Opening File VI_ERROR_INSTR_FILE_OPEN
BFFC0801	Error Writing to File VI_ERROR_INSTR_FILE_WRITE
BFFC0803	Invalid Response VI_ERROR_INSTR_INTERPRETING_RESPONSE
BFFC0809	Parameter 9 out of range. VI_ERROR_INSTR_PARAMETER9
BFFC080A	Parameter 10 out of range. VI_ERROR_INSTR_PARAMETER10
BFFC080B	Parameter 11 out of range. VI_ERROR_INSTR_PARAMETER11
BFFC080C	Parameter 12 out of range. VI_ERROR_INSTR_PARAMETER12
BFFF0000	Miscellaneous or system error occurred.
BFFF000E	Invalid session handle.
BFFF0015	Timeout occurred before operation could complete.
BFFF0034	Violation of raw write protocol occurred.
BFFF0035	Violation of raw read protocol occurred.
BFFF0036	Device reported an output protocol error.
BFFF0037	Device reported an input protocol error.
BFFF0038	Bus error occurred during transfer.
BFFF003A	Invalid setup (attributes are not consistent).
BFFF005F	No listeners condition was detected.
BFFF0060	This interface is not the controller in charge.
BFFF0067	Operation is not supported on this session.



PM1313B_PWR_TASK1

```
ViStatus PM1313B_pwr_Task1 (ViSession instrumentHandle, ViInt16 trigger,  
ViBoolean refOsc, ViInt16 dbm_Watt_Off, ViInt16 displayRate, unsigned short  
zero_Cal, float *pwrDisplay, ViChar _VI_FAR units[], ViPInt16 endZeroCal);
```

PURPOSE

This function is used in conjunction with **Pwr_Initialize** to set many basic parameters for power measurements.

PARAMETER LIST

instrumentHandle

Variable Type: **ViSession**

This control returns an **InstrumentHandle** that is used in all subsequent function calls to differentiate between different sessions of the instrument driver.

NOTE

Each time this function is invoked, a unique session is opened. It is possible to have more than one session open for the same resource.

trigger

Variable Type: **ViInt16**

This control allows the selection of one of three trigger modes: continuous, immediate or hold.

refOsc

Variable Type: **ViBoolean**

This control turns reference oscillator ON and OFF

dbm_Watt_Off

Variable Type: **ViInt16**

This control has three selections:

1. PM Off - turns power meter Off
2. Dbm - turns power meter ON (if it was OFF) and sets it to dBm mode of operation.
3. Watt - turns power meter ON (if it was OFF) and sets it to watt mode of operation.



displayRate

Variable Type: **viInt16**

This control allows the selection of the four display rates: fast, low, medium, and hold.

zero_Cal

Variable Type: unsigned short

This control allows selection of the following:

1. Zero - zero power meter
2. Cal - calibrate power meter
3. Zero&Cal - zero and then calibrate power meter
4. None.

Default: None

pwrDisplay

Variable Type: float (passed by reference)

This indicator displays power.

units

Variable Type: **viChar[]**

This indicator displays units of measurement: dBm or Watts.

endZeroCal

Variable Type: **viInt16** (passed by reference)

This indicator shows whether or not zero, cal, or zero&cal are in progress. If in progress, it is equal to 0. Otherwise it is 1.

RETURN VALUE

This control contains the status code returned by the function call.

Status Codes:

<u>Status</u>	<u>Description</u>
0	No error (the call was successful).
3FFC0101	ID Query not supported - VI_WARN_NSUP_ID_QUERY
3FFC0102	Reset not supported - VI_WARN_NSUP_RESET



3FFC0103	Self Test not supported - VI_WARN_NSUP_SELF_TEST
3FFC0104	Error Query not supported - VI_WARN_NSUP_ERROR_QUERY
3FFC0105	Revision Query not supported - VI_WARN_NSUP_REV_QUERY
3FFF0005	The specified termination character was read.
3FFF0006	The specified number of bytes was read.
BFFC0001	Parameter 1 out of range. (String not range checked)
BFFC0002	Parameter 2 (ID Query) out of range.
BFFC0003	Parameter 3 (Reset Device) out of range.
BFFC0004	Parameter 4 out of range.
BFFC0005	Parameter 5 out of range.
BFFC0006	Parameter 6 out of range.
BFFC0007	Parameter 7 out of range.
BFFC0008	Parameter 8 out of range.
BFFC0011	Instrument returned invalid response to ID Query
BFFC0800	Error Opening File VI_ERROR_INSTR_FILE_OPEN
BFFC0801	Error Writing to File VI_ERROR_INSTR_FILE_WRITE
BFFC0803	Invalid Response VI_ERROR_INSTR_INTERPRETING_RESPONSE
BFFC0809	Parameter 9 out of range. VI_ERROR_INSTR_PARAMETER9
BFFC080A	Parameter 10 out of range. VI_ERROR_INSTR_PARAMETER10
BFFC080B	Parameter 11 out of range. VI_ERROR_INSTR_PARAMETER11
BFFC080C	Parameter 12 out of range. VI_ERROR_INSTR_PARAMETER12
BFFF0000	Miscellaneous or system error occurred.
BFFF000E	Invalid session handle.
BFFF0015	Timeout occurred before operation could complete.
BFFF0034	Violation of raw write protocol occurred.
BFFF0035	Violation of raw read protocol occurred.
BFFF0036	Device reported an output protocol error.
BFFF0037	Device reported an input protocol error.
BFFF0038	Bus error occurred during transfer.
BFFF003A	Invalid setup (attributes are not consistent).
BFFF005F	No listeners condition was detected.
BFFF0060	This interface is not the controller in charge.
BFFF0067	Operation is not supported on this session.



PM1313B_PWR_TRIGGER_CONT

```
ViStatus PM1313B_pwr_trigger_cont (ViSession instrumentHandle);
```

PURPOSE

This function sets the trigger mode to CONTINUOUS.

PARAMETER LIST

instrumentHandle

Variable Type: **ViSession**

This control returns an **InstrumentHandle** that is used in all subsequent function calls to differentiate between different sessions of the instrument driver.

NOTE

Each time this function is invoked, a unique session is opened. It is possible to have more than one session open for the same resource.

RETURN VALUE

This control contains the status code returned by the function call.

Status Codes:

<u>Status</u>	<u>Description</u>
0	No error (the call was successful).
3FFC0101	ID Query not supported - VI_WARN_NSUP_ID_QUERY
3FFC0102	Reset not supported - VI_WARN_NSUP_RESET
3FFC0103	Self Test not supported - VI_WARN_NSUP_SELF_TEST
3FFC0104	Error Query not supported - VI_WARN_NSUP_ERROR_QUERY
3FFC0105	Revision Query not supported - VI_WARN_NSUP_REV_QUERY
3FFF0005	The specified termination character was read.
3FFF0006	The specified number of bytes was read.
BFFC0001	Parameter 1 out of range. (String not range checked)
BFFC0002	Parameter 2 (ID Query) out of range.
BFFC0003	Parameter 3 (Reset Device) out of range.
BFFC0004	Parameter 4 out of range.
BFFC0005	Parameter 5 out of range.
BFFC0006	Parameter 6 out of range.



BFFC0007	Parameter 7 out of range.
BFFC0008	Parameter 8 out of range.
BFFC0011	Instrument returned invalid response to ID Query
BFFC0800	Error Opening File VI_ERROR_INSTR_FILE_OPEN
BFFC0801	Error Writing to File VI_ERROR_INSTR_FILE_WRITE
BFFC0803	Invalid Response VI_ERROR_INSTR_INTERPRETING_RESPONSE
BFFC0809	Parameter 9 out of range. VI_ERROR_INSTR_PARAMETER9
BFFC080A	Parameter 10 out of range. VI_ERROR_INSTR_PARAMETER10
BFFC080B	Parameter 11 out of range. VI_ERROR_INSTR_PARAMETER11
BFFC080C	Parameter 12 out of range. VI_ERROR_INSTR_PARAMETER12
BFFF0000	Miscellaneous or system error occurred.
BFFF000E	Invalid session handle.
BFFF0015	Timeout occurred before operation could complete.
BFFF0034	Violation of raw write protocol occurred.
BFFF0035	Violation of raw read protocol occurred.
BFFF0036	Device reported an output protocol error.
BFFF0037	Device reported an input protocol error.
BFFF0038	Bus error occurred during transfer.
BFFF003A	Invalid setup (attributes are not consistent).
BFFF005F	No listeners condition was detected.
BFFF0060	This interface is not the controller in charge.
BFFF0067	Operation is not supported on this session.



PM1313B_PWR_TRIGGER_HOLD

```
ViStatus PM1313B_pwr_trigger_hold (ViSession instrumentHandle);
```

PURPOSE

This function sets the trigger mode to HOLD.

PARAMETER LIST

instrumentHandle

Variable Type : **ViSession**

This control returns an **InstrumentHandle** that is used in all subsequent function calls to differentiate between different sessions of the instrument driver.

NOTE

Each time this function is invoked, a unique session is opened. It is possible to have more than one session open for the same resource.

RETURN VALUE

This control contains the status code returned by the function call.

Status Codes:

<u>Status</u>	<u>Description</u>
0	No error (the call was successful).
3FFC0101	ID Query not supported - VI_WARN_NSUP_ID_QUERY
3FFC0102	Reset not supported - VI_WARN_NSUP_RESET
3FFC0103	Self Test not supported - VI_WARN_NSUP_SELF_TEST
3FFC0104	Error Query not supported - VI_WARN_NSUP_ERROR_QUERY
3FFC0105	Revision Query not supported - VI_WARN_NSUP_REV_QUERY
3FFF0005	The specified termination character was read.
3FFF0006	The specified number of bytes was read.
BFFC0001	Parameter 1 out of range. (String not range checked)
BFFC0002	Parameter 2 (ID Query) out of range.
BFFC0003	Parameter 3 (Reset Device) out of range.
BFFC0004	Parameter 4 out of range.
BFFC0005	Parameter 5 out of range.



BFFC0006	Parameter 6 out of range.
BFFC0007	Parameter 7 out of range.
BFFC0008	Parameter 8 out of range.
BFFC0011	Instrument returned invalid response to ID Query
BFFC0800	Error Opening File VI_ERROR_INSTR_FILE_OPEN
BFFC0801	Error Writing to File VI_ERROR_INSTR_FILE_WRITE
BFFC0803	Invalid Response VI_ERROR_INSTR_INTERPRETING_RESPONSE
BFFC0809	Parameter 9 out of range. VI_ERROR_INSTR_PARAMETER9
BFFC080A	Parameter 10 out of range. VI_ERROR_INSTR_PARAMETER10
BFFC080B	Parameter 11 out of range. VI_ERROR_INSTR_PARAMETER11
BFFC080C	Parameter 12 out of range. VI_ERROR_INSTR_PARAMETER12
BFFF0000	Miscellaneous or system error occurred.
BFFF000E	Invalid session handle.
BFFF0015	Timeout occurred before operation could complete.
BFFF0034	Violation of raw write protocol occurred.
BFFF0035	Violation of raw read protocol occurred.
BFFF0036	Device reported an output protocol error.
BFFF0037	Device reported an input protocol error.
BFFF0038	Bus error occurred during transfer.
BFFF003A	Invalid setup (attributes are not consistent).
BFFF005F	No listeners condition was detected.
BFFF0060	This interface is not the controller in charge.
BFFF0067	Operation is not supported on this session.



PM1313B_PWR_TRIGGER_IMM

```
ViStatus PM1313B_pwr_trigger_imm (ViSession instrumentHandle);
```

PURPOSE

This function sets the trigger mode to IMMEDIATE.

PARAMETER LIST

instrumentHandle

Variable Type: **ViSession**

This control returns an **InstrumentHandle** that is used in all subsequent function calls to differentiate between different sessions of the instrument driver.

NOTE

Each time this function is invoked, a unique session is opened. It is possible to have more than one session open for the same resource.

RETURN VALUE

This control contains the status code returned by the function call.

Status Codes:

<u>Status</u>	<u>Description</u>
0	No error (the call was successful).
3FFC0101	ID Query not supported - VI_WARN_NSUP_ID_QUERY
3FFC0102	Reset not supported - VI_WARN_NSUP_RESET
3FFC0103	Self Test not supported - VI_WARN_NSUP_SELF_TEST
3FFC0104	Error Query not supported - VI_WARN_NSUP_ERROR_QUERY
3FFC0105	Revision Query not supported - VI_WARN_NSUP_REV_QUERY
3FFF0005	The specified termination character was read.
3FFF0006	The specified number of bytes was read.
BFFC0001	Parameter 1 out of range. (String not range checked)
BFFC0002	Parameter 2 (ID Query) out of range.
BFFC0003	Parameter 3 (Reset Device) out of range.
BFFC0004	Parameter 4 out of range.
BFFC0005	Parameter 5 out of range.



BFFC0006	Parameter 6 out of range.
BFFC0007	Parameter 7 out of range.
BFFC0008	Parameter 8 out of range.
BFFC0011	Instrument returned invalid response to ID Query
BFFC0800	Error Opening File VI_ERROR_INSTR_FILE_OPEN
BFFC0801	Error Writing to File VI_ERROR_INSTR_FILE_WRITE
BFFC0803	Invalid Response VI_ERROR_INSTR_INTERPRETING_RESPONSE
BFFC0809	Parameter 9 out of range. VI_ERROR_INSTR_PARAMETER9
BFFC080A	Parameter 10 out of range. VI_ERROR_INSTR_PARAMETER10
BFFC080B	Parameter 11 out of range. VI_ERROR_INSTR_PARAMETER11
BFFC080C	Parameter 12 out of range. VI_ERROR_INSTR_PARAMETER12
BFFF0000	Miscellaneous or system error occurred.
BFFF000E	Invalid session handle.
BFFF0015	Timeout occurred before operation could complete.
BFFF0034	Violation of raw write protocol occurred.
BFFF0035	Violation of raw read protocol occurred.
BFFF0036	Device reported an output protocol error.
BFFF0037	Device reported an input protocol error.
BFFF0038	Bus error occurred during transfer.
BFFF003A	Invalid setup (attributes are not consistent).
BFFF005F	No listeners condition was detected.
BFFF0060	This interface is not the controller in charge.
BFFF0067	Operation is not supported on this session.



PM1313B_PWR_WATT

```
ViStatus PM1313B_pwr_watt (ViSession instrumentHandle);
```

PURPOSE

This function sets power meter units to WATTS.

PARAMETER LIST

instrumentHandle

Variable Type: **ViSession**

This control returns an **InstrumentHandle** that is used in all subsequent function calls to differentiate between different sessions of the instrument driver.

NOTE

Each time this function is invoked, a unique session is opened. It is possible to have more than one session open for the same resource.

RETURN VALUE

This control contains the status code returned by the function call.

Status Codes:

<u>Status</u>	<u>Description</u>
0	No error (the call was successful).
3FFC0101	ID Query not supported - VI_WARN_NSUP_ID_QUERY
3FFC0102	Reset not supported - VI_WARN_NSUP_RESET
3FFC0103	Self Test not supported - VI_WARN_NSUP_SELF_TEST
3FFC0104	Error Query not supported - VI_WARN_NSUP_ERROR_QUERY
3FFC0105	Revision Query not supported - VI_WARN_NSUP_REV_QUERY
3FFF0005	The specified termination character was read.
3FFF0006	The specified number of bytes was read.
BFFC0001	Parameter 1 out of range. (String not range checked)
BFFC0002	Parameter 2 (ID Query) out of range.
BFFC0003	Parameter 3 (Reset Device) out of range.
BFFC0004	Parameter 4 out of range.
BFFC0005	Parameter 5 out of range.
BFFC0006	Parameter 6 out of range.



BFFC0007	Parameter 7 out of range.
BFFC0008	Parameter 8 out of range.
BFFC0011	Instrument returned invalid response to ID Query
BFFC0800	Error Opening File VI_ERROR_INSTR_FILE_OPEN
BFFC0801	Error Writing to File VI_ERROR_INSTR_FILE_WRITE
BFFC0803	Invalid Response VI_ERROR_INSTR_INTERPRETING_RESPONSE
BFFC0809	Parameter 9 out of range. VI_ERROR_INSTR_PARAMETER9
BFFC080A	Parameter 10 out of range. VI_ERROR_INSTR_PARAMETER10
BFFC080B	Parameter 11 out of range. VI_ERROR_INSTR_PARAMETER11
BFFC080C	Parameter 12 out of range. VI_ERROR_INSTR_PARAMETER12
BFFF0000	Miscellaneous or system error occurred.
BFFF000E	Invalid session handle.
BFFF0015	Timeout occurred before operation could complete.
BFFF0034	Violation of raw write protocol occurred.
BFFF0035	Violation of raw read protocol occurred.
BFFF0036	Device reported an output protocol error.
BFFF0037	Device reported an input protocol error.
BFFF0038	Bus error occurred during transfer.
BFFF003A	Invalid setup (attributes are not consistent).
BFFF005F	No listeners condition was detected.
BFFF0060	This interface is not the controller in charge.
BFFF0067	Operation is not supported on this session.



PM1313B_PWR_ZERO

```
ViStatus PM1313B_pwr_zero (ViSession instrumentHandle);
```

PURPOSE

This function is utilized to perform power sensor zeroing.

PARAMETER LIST

instrumentHandle

Variable Type: **ViSession**

This control returns an **InstrumentHandle** that is used in all subsequent function calls to differentiate between different sessions of the instrument driver.

NOTE

Each time this function is invoked, a unique session is opened. It is possible to have more than one session open for the same resource.

RETURN VALUE

This control contains the status code returned by the function call.

Status Codes:

<u>Status</u>	<u>Description</u>
0	No error (the call was successful).
3FFC0101	ID Query not supported - VI_WARN_NSUP_ID_QUERY
3FFC0102	Reset not supported - VI_WARN_NSUP_RESET
3FFC0103	Self Test not supported - VI_WARN_NSUP_SELF_TEST
3FFC0104	Error Query not supported - VI_WARN_NSUP_ERROR_QUERY
3FFC0105	Revision Query not supported - VI_WARN_NSUP_REV_QUERY
3FFF0005	The specified termination character was read.
3FFF0006	The specified number of bytes was read.
BFFC0001	Parameter 1 out of range. (String not range checked)
BFFC0002	Parameter 2 (ID Query) out of range.
BFFC0003	Parameter 3 (Reset Device) out of range.
BFFC0004	Parameter 4 out of range.
BFFC0005	Parameter 5 out of range.
BFFC0006	Parameter 6 out of range.



BFFC0007	Parameter 7 out of range.
BFFC0008	Parameter 8 out of range.
BFFC0011	Instrument returned invalid response to ID Query
BFFC0800	Error Opening File VI_ERROR_INSTR_FILE_OPEN
BFFC0801	Error Writing to File VI_ERROR_INSTR_FILE_WRITE
BFFC0803	Invalid Response VI_ERROR_INSTR_INTERPRETING_RESPONSE
BFFC0809	Parameter 9 out of range. VI_ERROR_INSTR_PARAMETER9
BFFC080A	Parameter 10 out of range. VI_ERROR_INSTR_PARAMETER10
BFFC080B	Parameter 11 out of range. VI_ERROR_INSTR_PARAMETER11
BFFC080C	Parameter 12 out of range. VI_ERROR_INSTR_PARAMETER12
BFFF0000	Miscellaneous or system error occurred.
BFFF000E	Invalid session handle.
BFFF0015	Timeout occurred before operation could complete.
BFFF0034	Violation of raw write protocol occurred.
BFFF0035	Violation of raw read protocol occurred.
BFFF0036	Device reported an output protocol error.
BFFF0037	Device reported an input protocol error.
BFFF0038	Bus error occurred during transfer.
BFFF003A	Invalid setup (attributes are not consistent).
BFFF005F	No listeners condition was detected.
BFFF0060	This interface is not the controller in charge.
BFFF0067	Operation is not supported on this session.



PM1313B_REGISTER_STATUS

```
ViStatus PM1313B_register_status (ViSession instrumentHandle, ViPUInt16  
lowBandCtrlReg_Offset200H, ViPUInt16 pathCtrlReg_Offset202H, ViPUInt16  
attRFCtrlReg_Offset204H, ViPUInt16 YIGCtrlReg_Offset206H, ViPUInt16  
statusReg_Offset200HRead);
```

PURPOSE

This function allows the user to query the low-level register status of all of the registers used with the downconverter. This function can be used to check the register values set on the downconverter for monitoring purposes.

PARAMETER LIST

instrumentHandle

Variable Type: **ViSession**

This control accepts the **InstrumentHandle** returned by the **Initialize** function to select the desired instrument driver session.

Default Value: None

lowBandCtrlReg_Offset200H

Variable Type: **ViUInt16** (passed by reference)

This control reads the low-band control register values offset from 200H.

pathCtrlReg_Offset202H

Variable Type: **ViUInt16** (passed by reference)

This control reads the path control register values offset from 202H.

attRFCtrlReg_Offset204H

Variable Type: **ViUInt16** (passed by reference)

This control sets the attenuator control register values offset from 204H.

YIGCtrlReg_Offset206H

Variable Type: **ViUInt16** (passed by reference)

This control reads the YIG control register values offset from 206H.



statusReg_Offset200HRead

Variable Type: **viUInt16** (passed by reference)

This control reads the status register values offset from 202H.

RETURN VALUE

Every driver function returns a status value that indicates whether or not the function was executed successfully.

Normal Return: **VI_SUCCESS**

Error Return: Call function **pm1313b_error_message ()** to get the message this code represents.



PM1313B_RESET

```
ViStatus PM1313B_reset (ViSession instrumentHandle);
```

PURPOSE

This function resets the downconverter.

PARAMETER LIST

instrumentHandle

Variable Type: **ViSession**

This control accepts the **InstrumentHandle** returned by the **Initialize** function to select the desired instrument driver session.

Default Value: None

RETURN VALUE

Every driver function returns a status value that indicates whether or not the function was executed successfully.

Normal Return: **VI_SUCCESS**

Error Return: Call function **pm1313b_error_message()** to get the message this code represents.



PM1313B_SET_BYPASS_AMP_STATE

ViStatus PM1313B_set_bypass_amp_state (ViSession instrumentHandle, ViUInt16 setBypassAmp);

PURPOSE

This function sets the state of the bypass amplifier between ON and OFF.

PARAMETER LIST

instrumentHandle

Variable Type: **ViSession**

This control accepts the **InstrumentHandle** returned by the **Initialize** function to select the desired instrument driver session.

Default Value: None

setBypassAmp

Variable Type: **ViUInt16**

This control sets the state of the bypass amplifier between ON and OFF.

Valid Range:

- LOWFREQ_AMP_OFF 0
- LOWFREQ_AMP_ON 1

Default:

- LOWFREQ_AMP_OFF 0

RETURN VALUE

Every driver function returns a status value that indicates whether or not the function was executed successfully.

Normal Return: **VI_SUCCESS**

Error Return: Call function **pm1313b_error_message ()** to get the message this code represents.



PM1313B_SET_DETECTOR_TIME

```
ViStatus PM1313B_set_detector_time (ViSession instrumentHandle, ViUInt16  
setDetectorTime);
```

PURPOSE

This function sets the detector response between FAST and SLOW.

PARAMETER LIST

instrumentHandle

Variable Type: **ViSession**

This control accepts the **InstrumentHandle** returned by the **Initialize** function to select the desired instrument driver session.

Default Value: None

setDetectorTime

Variable Type: **ViUInt16**

This control specifies the linear detector response type.

Valid Range:

- DETECTOR_FAST 0
- DETECTOR_SLOW 1

Default:

- DETECTOR_FAST 0

RETURN VALUE

Every driver function returns a status value that indicates whether or not the function was executed successfully.

Normal Return: **VI_SUCCESS**

Error Return: Call function **pm1313b_error_message ()** to get the message this code represents.



PM1313B_SET_FILTER

```
ViStatus PM1313B_set_filter (ViSession instrumentHandle, ViUInt16 setFilter);
```

PURPOSE

This function sets the filter bandwidths to one of the following settings

Variable type: **viUInt16**

Valid Range:

- FILTER_500 KHz
- FILTER_8 MHz
- FILTER_50 KHz
- FILTER_2 MHz

Default:

- Filter_500 KHz

PARAMETER LIST

instrumentHandle

Variable Type: **ViSession**

This control accepts the **InstrumentHandle** returned by the **Initialize** function to select the desired instrument driver session.

Default Value: None

setFilter

Variable Type: **viUInt16**

This control specifies the filter bandwidths for PM1313B to one of the following settings selected from the list:

- | | |
|------------------|---|
| - FILTER_500 KHz | 0 |
| - FILTER_8 MHz | 1 |
| - FILTER_2 MHz | 2 |
| - FILTER_50 KHz | 3 |



RETURN VALUE

Every driver function returns a status value that indicates whether or not the function was executed successfully.

Normal Return: **VI_SUCCESS**

Error Return: Call function **pm1313b_error_message ()** to get the message this code represents.



PM1313B_SET_Highband_PREAMP_STATE

```
ViStatus PM1313B_set_highband_preAmp_state (ViSession instrumentHandle,  
ViUInt16 seHighbandPreAmp);
```

PURPOSE

This function sets the state of the high-band preamplifier between ON and OFF.

PARAMETER LIST

instrumentHandle

Variable Type: **ViSession**

This control accepts the **InstrumentHandle** returned by the **Initialize** function to select the desired instrument driver session.

Default Value: None

seHighbandPreAmp

Variable Type: **ViUInt16**

This control sets the state of the high-band preamplifier between ON and OFF.

Valid Range:

- HIGHBAND_PREAMP_OFF 0
- HIGHBAND_PREAMP_ON 1

Default:

- HIGHBAND_PREAMP_OFF 0

RETURN VALUE

Every driver function returns a status value that indicates whether or not the function was executed successfully.

Normal Return: **VI_SUCCESS**

Error Return: Call function **pm1313b_error_message ()** to get the message this code represents.



PM1313B_SET_IF_GAIN_1

```
ViStatus PM1313B_set_if_gain (ViSession instrumentHandle, ViReal64 attenuation);
```

PURPOSE

This function sets the instrument IF gain settings. IF Gain control sets the IF Gain from 0dB through 31.5dB.

Minimum gain value is 0.0dB

Maximum gain value is 31.5dB

Step size for gain value is 0.5dB

Default IF Gain value is 0dB.

PARAMETER LIST

instrumentHandle

Variable Type: **ViSession**

This control accepts the **InstrumentHandle** returned by the **Initialize** function to select the desired instrument driver session.

Default Value: None

attenuation

Variable Type: **ViReal64**

This control specifies the IF gain for channel 1.

Valid Range:

- Minimum: 0.5 dB
- Maximum: 31.5 dB
- Default: 0.0 dB

RETURN VALUE

Every driver function returns a status value that indicates whether or not the function was executed successfully.

Normal Return: **VI_SUCCESS**

Error Return: Call function **pm1313b_error_message ()** to get the message this code represents.



PM1313B_SET_IF_GAIN_2

```
ViStatus PM1313B_set_if_gain (ViSession instrumentHandle, ViReal64 attenuation);
```

PURPOSE

This function sets the instrument IF gain settings. IF Gain control sets the IF Gain from 0dB through 31.5dB.

Minimum gain value is 0.0dB

Maximum gain value is 31.5dB

Step size for gain value is 0.5dB

Default IF Gain value is 0dB.

PARAMETER LIST

instrumentHandle

Variable Type: **ViSession**

This control accepts the **InstrumentHandle** returned by the **Initialize** function to select the desired instrument driver session.

Default Value: None

attenuation

Variable Type: **ViReal64**

This control specifies the IF gain for channel 1.

Valid Range:

- Minimum: 0.5 dB
- Maximum: 31.5 dB
- Default: 0.0 dB

RETURN VALUE

Every driver function returns a status value that indicates whether or not the function was executed successfully.

Normal Return: **VI_SUCCESS**

Error Return: Call function **pm1313b_error_message ()** to get the message this code represents.

PM1313B_SET_IF_OUTPUT_PATH

```
ViStatus PM1313B_set_if_output_path (ViSession instrumentHandle, ViUInt16
setIFOutputPath);
```

PURPOSE

This function sets the IF output path between IF 1 and IF 2. When IF 1 is selected, AUX IF is turned off.

PARAMETER LIST

instrumentHandle

Variable Type: **ViSession**

This control accepts the **InstrumentHandle** returned by the **Initialize** function to select the desired instrument driver session.

Default Value: None

setIFOutputPath

Variable Type: **ViUInt16**

This control sets the IF output path between IF 1 and IF 2.

Valid Range:

- ROUTE_TO_IF1 0
- ROUTE_TO_IF2 1

Default:

- ROUTE_TO_IF1 0

RETURN VALUE

Every driver function returns a status value that indicates whether or not the function was executed successfully.

Normal Return: **VI_SUCCESS**

Error Return: Call function **pm1313b_error_message()** to get the message this code represents.

RETURN VALUE

Every driver function returns a status value that indicates whether or not the function was executed successfully.

Normal Return: **VI_SUCCESS**

Error Return: Call function **pm1313b_error_message ()** to get the message this code represents.



PM1313B_SET_LOWBAND_SIGNAL_PATH

```
ViStatus PM1313B_set_lowband_signal_path (ViSession instrumentHandle, ViUInt16  
lowbandSignal_path);
```

PURPOSE

This function allows the user to select the RF-input-signal path for through the low-band module of the downconverter.

PARAMETER LIST

instrumentHandle

Variable Type: **ViSession**

This control accepts the **InstrumentHandle** returned by the **Initialize** function to select the desired instrument driver session.

Default Value: None

lowbandSignal_path

Variable Type: **ViUInt16**

This control specifies the output signal path for downconverter.

Valid Range:

- BYPASS 1
- LOWBAND 2
- HIGHBAND 3

Default:

- HIGHBAND 3

NOTE

BYPASS2: Allows RF signal (100 KHz to 100 MHz) to be bypassed through the downconverter. LOWBAND: Allows RF signal (100 KHz to 2.9 GHz) to be downconverted to IF level. HIGHBAND: Turns off low-band module.

RETURN VALUE

Every driver function returns a status value that indicates whether or not the function was executed successfully.

Normal Return: **VI_SUCCESS**

Error Return: Call function **pm1313b_error_message ()** to get the message this code represents.

PM1313B_SET_STEP_ATTENUATOR

```
ViStatus PM1313B_set_step_attenuator (ViSession instrumentHandle, ViUInt16
selectAttenType, ViUInt16 setAttenuator);
```

PURPOSE

This function allows the user to set 70 dB or 90 dB attenuator up or down by 10 dB step.

PARAMETER LIST

instrumentHandle

Variable Type: **ViSession**

This control accepts the **InstrumentHandle** returned by the **Initialize** function to select the desired instrument driver session.

Default Value: None

selectAttenType

Variable Type: **ViUInt16**

This control specifies which attenuator is selected.

Valid Range:

- PM1313B_70dB 0
- PM1313B_90dB 1

Default:

- PM1313B_70dB 0

setAttenuator

Variable Type: **ViUInt16**

This control specifies the attenuator level.

Valid Range:

- PM1313B_Atten_0dB 0
- PM1313B_Atten_10dB 1
- PM1313B_Atten_20dB 2
- PM1313B_Atten_30dB 3



- PM1313B_Atten_40dB 4
- PM1313B_Atten_50dB 5
- PM1313B_Atten_60dB 6
- PM1313B_Atten_70dB 7
- PM1313B_Atten_80dB 8
- PM1313B_Atten_90dB 9

Default:

- PM1313B_Atten_40dB 4

RETURN VALUE

Every driver function returns a status value that indicates whether or not the function was executed successfully.

Normal Return: **VI_SUCCESS**

Error Return: Call function **pm1313b_error_message()** to get the message this code represents.

PM1313B_SET_WIDEBAND_STATE

```
ViStatus PM1313B_set_wideband_state (ViSession instrumentHandle, ViUInt16
setWidebandState);
```

PURPOSE

This function sets the wideband state (100 KHz to 100 MHz). With this function, the user can select or bypass the signal through the IF-processor module.

PARAMETER LIST

instrumentHandle

Variable Type: **ViSession**

This control accepts the **InstrumentHandle** returned by the **Initialize** function to select the desired instrument driver session.

Default Value: None

setWidebandState

Variable Type: **ViUInt16**

This control sets the wideband path state between wideband or bypass.

Valid Range:

- WIDEBAND_OFF 0
- WIDEBAND_ON 1

Default:

- WIDEBAND_OFF 0

RETURN VALUE

Every driver function returns a status value that indicates whether or not the function was executed successfully.

Normal Return: **VI_SUCCESS**

Error Return: Call function **pm1313b_error_message ()** to get the message this code represents.



PM1313B_SET_YIG_FREQUENCY

```
ViStatus PM1313B_set_yig_frequency (ViSession instrumentHandle, float  
YIGFrequency_GHz);
```

PURPOSE

This function sets the YIG frequency in GHz to provide 50 MHz filter bandwidth around center frequency of input signal.

PARAMETER LIST

instrumentHandle

Variable Type: **ViSession**

This control accepts the **InstrumentHandle** returned by the **Initialize** function to select the desired instrument driver session.

Default Value: None

YIGFrequency_GHz

Variable Type: float

This control sets the YIG frequency in GHz.

Minimum Value: 0 Hz

Maximum Value: 27 GHz

Default Value: 0 Hz

RETURN VALUE

Every driver function returns a status value that indicates whether or not the function was executed successfully.

Normal Return: **VI_SUCCESS**

Error Return: Call function **pm1313b_error_message ()** to get the message this code represents.

PM1313B_SET_YIG_STATE

```
ViStatus PM1313B_set_yig_state (ViSession instrumentHandle, ViUInt16  
setYIGPreSelectPath);
```

PURPOSE

This function sets the YIG pre-select path for downconverter.

PARAMETER LIST

instrumentHandle

Variable Type: **ViSession**

This control accepts the **InstrumentHandle** returned by the **Initialize** function to select the desired instrument driver session.

Default Value: None

setYIGPreSelectPath

Variable Type: **ViUInt16**

This control specifies the YIG pre-select path.

Valid Range:

- PM1313B_YIG_PRE_SELECT0
- PM1313B_YIG_DIRECT_PATH1

Default:

- PM1313B_YIG_PRE_SELECT0

RETURN VALUE

Every driver function returns a status value that indicates whether or not the function was executed successfully.

Normal Return: **VI_SUCCESS**

Error Return: Call function **pm1313b_error_message ()** to get the message this code represents.



PM1313B_UPDATE_REGISTER_VALUE

```
void PM1313B_update_register_value (ViUInt16 registerValue_IN, ViUInt16  
registerMASK, ViUInt16 subRegisterValue, ViPUInt16 registerValue_OUT);
```

PARAMETER LIST

registerValue_IN

Variable Type: **ViUInt16**

registerMASK

Variable Type: **ViUInt16**

subRegisterValue

Variable Type: **ViUInt16**

registerValue_OUT

Variable Type: **ViUInt16** (passed by reference)

6

DIRECT REGISTER PROGRAMMING

INTRODUCTION

The Phase Matrix 1313B is a register-based, A16/A24, VXIbus Instrument. The A16 configuration registers contain basic information about the module, including the manufacturer ID, the device type, status/control, and the A24 offset address. All programming of the 1313B is accomplished by writing to the control registers located in the A24 address space. The function of each register is defined in this section.

BASIC CONFIGURATION REGISTERS

MANUFACTURER ID REGISTER (READ ONLY)

Bits 0 through 11 of the Manufacturer ID Register contain the manufacturer's ID. Bits 12 and 13 establish the address space supported. Bits 14 and 15 establish the device class.

The Manufacturer ID number for Phase Matrix is 3680. This number is programmed into bits 0 through 11 of the Manufacturer ID Register and cannot be changed.

Phase Matrix Manufacturer ID # = 3680 decimal = 1110 0110 0000 binary

The 1313B supports both A16 and A24 addressing modes. Per the VXIbus standard, bits 12 and 13 identify the addressing modes supported by the instrument. For instruments supporting A16/A24 addressing modes, both bits 12 and 13 have values of zero.

Address Space = A16/A24 \Rightarrow b12 = 0 and b13 = 0



Manufacturer ID Register (b+00_{HEX})

Bit #	15	14	13	12	11	10	9	8	7	6	5	4	3	2	1	0
Write	Not Defined															
Read	1	1	0	0	1	1	1	0	0	1	1	0	0	0	0	0

Per the VXIbus standard, bits 14 and 15 indicate the device class. For register-based instruments, both bits 14 and 15 have values of one.

Device Class = Register Based ⇒ b14 = 1 and b15 = 1

DEVICE TYPE REGISTER (READ ONLY)

Bits 0 through 11 of the Device Type Register contain the model code for the instrument. For the Phase Matrix 1313B, the model code is 1313.

Model Code = 1313 decimal = 0101 0010 0001 binary

Bits 12 through 15 of the Device Type Register establish the memory requirements for A16/A24 and A16/A32 devices. The resource manager uses this information when allocating memory for the system.

The following formula is used to determine the contents of bits 12 through 15 based on the memory requirements of the instrument:

Required memory = 256^a x 2^{23-m}

where: a = contents of address space field in ID register.

a = 00 for the 1313B.

m = required memory in integer increments of 2ⁿ.
The 1313B needs 1304 bytes, so the allotted memory is 2048 bytes.

2ⁿ = 2048 ⇒ n = 11

2¹¹ = 2⁽²³⁻¹²⁾ ⇒ m = 12

12 decimal = 1100 binary

Device Type Register = 1100 0101 0010 0001

Device Type Register (b+02_{HEX})

Bit #	15	14	13	12	11	10	9	8	7	6	5	4	3	2	1	0
Write	Not Defined															
Read	1	1	0	0	0	1	0	1	0	0	1	0	0	0	0	1

STATUS/CONTROL REGISTER (READ/WRITE)

This register serves a dual function in the 1313B by providing both status information and limited control of the instrument. The status information is obtained by reading the contents of this register. At power-up, the 1313B goes through an initialization routine and writes a one (1) to bit 3 of the Status Register when the initialization routine is complete. If the 1313B does not detect a problem during the initialization routine, it writes a one (1) to bit 2, indicating that it is ready to begin normal operation. At power-up, the resource manager reads this register to verify that the 1313B has passed initialization and is ready to execute commands.

Status/Control Register (b+04_{HEX})

Bit #	15	14	13	12	11	10	9	8	7	6	5	4	3	2	1	0
Contents																

The resource manager can also write to specific bits in this register to control the instrument. In the 1313B, bits 0, 1, and 15 are the only control bits that are used. To execute a soft reset of the 1313B, the resource manager writes a one (1) to bit 0. If the resource manager writes a one (1) to bit 1 of the control register, the 1313B does not drive the SYSFAIL* line low in response to a system failure. To enable access to A24 address-space memory contained in the 1313B, the resource manager writes a one (1) to bit 15 of the control register. Per the VXIbus specification, the resource manager writes ones to the device-dependent bits of the control register whenever it writes to the control register.

OFFSET REGISTER FOR A24 (READ/WRITE)

The Offset Register contains the base address of the A24 address space. At power-up, the resource manager reads the Required Memory bits of the Device Type register and the Logical Address from the address switches to generate an offset value, which it writes to the A16 Offset register. The content of the Offset Register is concatenated with the Offset Address of the various command and response registers to generate the actual address of these command and response registers in the A24 address space.



A16 REGISTERS 08_{HEX} - 3F_{HEX} NOT USED

A24 REGISTERS

Offset (HEX)	Description
000 _{HEX} - IFF _{HEX}	Not Used
200 _{HEX} (Write)	IF-Gain Control and Low-Band-Control register (16 bits, latched control lines)
200 _{HEX} (Read)	Status register (16 bits)
202 _{HEX} (Write)	IF-Path-Control register (16 bits, latched control lines)
204 _{HEX} (Write)	Step-Attenuator and RF-Path-Control register (16 bits, latched control lines)
206 _{HEX} (Write)	YIG Control (16 bits — tunes the YIG)
20E _{HEX} (Write)	Second IF-Gain Control

IF-GAIN CONTROL AND LOW-BAND-CONTROL REGISTER (OFFSET + 200_{HEX})

This register controls the IF gain and selects the signal path through the Low-Band module.

IF Gain and Lowband Control Offset (Offset + 200_{HEX})

Bit #	15	14	13	12	11	10	9	8	7	6	5	4	3	2	1	0
Write							X	X			16	8	4	2	1	.5
Read	Defined Below															

Bits 0-5 These bits control the Channel 1 IF gain. A high state adds the amount of gain corresponding to that bit. For example, if bits 0 through 4 are high, and bit 5 is low, the gain is set to 15.5 dB.

Bit	Attenuation
0	= 0.5 dB
1	= 1 dB
2	= 2 dB
3	= 4 dB
4	= 8 dB
5	= 16 dB

Bits 6-7 Not used

IF-GAIN CONTROL AND LOW-BAND-CONTROL REGISTER (OFFSET + 200_{HEX}) (CONTINUED)

Bits 8-9 These bits select the signal path through the Low-Band module. CTL_A controls the A1K1 switch, which routes LO1 to the high band or the low band. CTL_B controls the A1K2 switch, which routes the input signal to the low-band bypass path or to the low-band downconverter.

Bit 8 CTL_A	Bit 9 CTL_B	Description
0	0	= High Band/Aux — Low-Band Module turned OFF
1	0	= Low-Band Downconverted path — Bypass path OFF
0	1	= Low-Band Bypass path — Downconverted path OFF
1	1	= Invalid mode

Bit 10-15 Not used

STATUS REGISTER (OFFSET + 200_{HEX})

Bits 0-15 This register contains 16-bit status information. A high bit indicates that the corresponding hardware is functional. Thus, a reading of XFFF_{HEX} from this register indicates that the unit is completely functional. B

IF Gain and Lowband Control Register (Offset + 200_{HEX})

Bit #	15	14	13	12	11	10	9	8	7	6	5	4	3	2	1	0
Write	Defined Above															
Read					OVLD	LO3*	LO2	LO1	1	1	1	+5	-10	-21	+21	+10
	Not Used				Signal Monitor				Not Used			Voltage Monitor				

The format for this register is:

Bit	Description
0	+10 Volt supply
1	+21 Volt supply
2	-21 Volt supply
3	-10 Volt supply
4	+5 Volt supply
5	Always high (not used)
6	Always high (not used)
7	Always high (not used)



STATUS REGISTER (OFFSET + 200_{HEX}) (CONTINUED)

Bit	Description
8	LO 1 Sense (Indicates that the 3-9 GHz LO is present, Low-Band Module A1)
9	LO 2 Sense (Indicates that the 3.25 GHz LO is present, Low-Band Module A1)
10	LO 3 Sense (Indicates that the 228 MHz LO is present, IF Processor Module A2)
11	Overload (Indicates that the IF section is being overdriven, IF Processor Module A2)
12-15	Not used

IF PATH CONTROL REGISTER (OFFSET + 202_{HEX})

This register controls the various digital-control bits to the IF-Processor module (A2). These bits control the input-signal MUX (A2K1), output filters (A2K12, A2K13), IF path (AUX IF / wideband), IF Bypass, and power to some amplifiers.

IF Path Control Register (Offset + 202_{HEX})

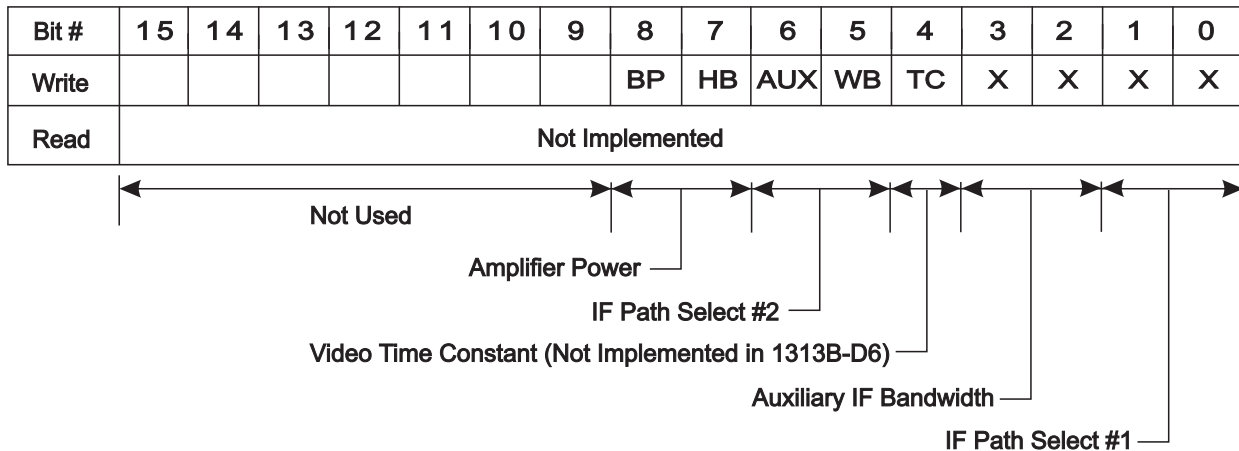

Bits 0-1 These bits control the input IF MUX (A2K1). They select between four possible input signals to the IF Processor module, only two of which are used in the 1313B (Low-Band and High-Band).

Mode	Bit 0 HFSELA	BIT 1 HFSELB
Not used	0	0
Low-Band	1	0
Not used	0	1
High-Band	1	1

IF PATH CONTROL REGISTER (OFFSET + 202_{HEX}) (CONTINUED)

Bits 2-3 These bits control the output-filter selection of the Auxiliary IF Path (A2K12, A2K13). They select between four possible output filters (50 kHz, 500 kHz, 2 MHz, and 8 MHz).

<u>Mode</u>	<u>Bit 2 21SelA</u>	<u>BIT 3 21SELB</u>
500 kHz	0	0
8 MHz	1	0
50 kHz	0	1
2 MHz	1	1

Bit 4 Not used in the 1313B.

Bit 5 This bit selects between 100 kHz–100 MHz straight-through bypass or the Wideband path via (A2K2).

<u>Mode</u>	<u>BIT 5 WB_ON</u>
Bypass (100 kHz–100 MHz) path (wideband power OFF)	0
Wideband path (wideband power ON)	1

Bit 6 This bit routes the IF straight through to the “I.F.1 Out” or through the AUX IF path (downconverted to 21.4 MHz) to “I.F.2 Out” via (A2K11).

<u>Mode</u>	<u>BIT 6 CONV_ON</u>
IF routed straight through to I.F.1 Out (AUX IF power OFF)	0
IF routed through Baseband to I.F.2 Out	1

Bit 7 This bit controls the DC power to the High-Band preamplifier.

<u>Mode</u>	<u>BIT 7 HB_AMP_ON</u>
High-Band preamplifier power OFF	0
High-Band preamplifier power ON	1

Bit 8 This bit controls the DC power to the low-frequency amplifier in the bypass path.

<u>Mode</u>	<u>BIT 8 ENB_LF</u>
Bypass Amplifier power OFF	0
Bypass Amplifier power ON	1

Bits 9-15 Not used



STEP ATTENUATOR AND RF-PATH CONTROL REGISTER (OFFSET + 204_{HEX})

This register controls the input Step.

Bit #	15	14	13	12	11	10	9	8	7	6	5	4	3	2	1	0
Write							RF	YIG					*	X	X	X
Read	Not Implemented															

← Not Used
RF Path
Not Used
Step Attenuator →

Bits 0-3 These bits control the Step Attenuator.

70 dB Attenuator

- Bit 0 = AT11 (10 dB)
- Bit 1 = AT31 (20 dB)
- Bit 2 = AT21 (40 dB)
- Bit 3* = Reserved

<u>Attenuation</u>	<u>Bit 3</u>	<u>Bit 2</u>	<u>Bit 1</u>	<u>Bit 0</u>
0 db	1	1	1	1
10 dB	1	1	1	0
20 dB	1	1	0	1
30 dB	1	1	0	0
40 dB	1	0	1	1
50 dB	1	0	1	0
60 dB	1	0	0	1
70 dB	1	0	0	0

* Bit 3 reserved for alternate attenuator. Not implemented in 1313B.

Bits 4-7 Not used

Bit 8 This bit selects the YIG Pre-selector path (A7K1, A7K2):

<u>Mode</u>	<u>Bit 8 YIG_SEL</u>
YIG Pre-selector path	1
Direct path	0

STEP ATTENUATOR AND RF-PATH CONTROL REGISTER (OFFSET + 204_{HEX}) (CONTINUED)

Bit 9 This bit selects the High-Band/Low-Band path(A7K0):

Mode	Bit 9
	HIGH_BAND_SEL
High Band path	1
Low Band path	0

Bits 10-15 Not used

YIG-CONTROL REGISTER (OFFSET + 206_{HEX})

This register tunes the YIG bandpass filter in the High Band RF Path to the desired center frequency. All 0s (0000_{HEX}) programs the YIG to 0 GHz, while all 1s (FFFF_{HEX}) programs the YIG to 27.0 GHz. Each LSB steps the YIG approximately 411994 Hz (27.0 GHz/65535).

To program the YIG to a specific frequency, divide the frequency by 411994 Hz, convert the result to binary, and load that number into the register.

Example: To program the YIG to 10.125 GHz, calculate:

$$10.125 \times 10^9 / 411994 = 24,527_{\text{DEC}} = 5FCF_{\text{HEX}} = 0101\ 1111\ 1100\ 1111_{\text{BIN}}$$

Note, however, that the specified useful range of the YIG is 2.7 GHz to 26.5 GHz, and its specified tuning accuracy is ± 20 MHz. Hence, the step size may vary slightly across the band. Furthermore, as numbers much below 2000_{HEX} are entered, the YIG insertion loss increases beyond the point of usability. See Section 7, "Calibration," for the procedure for setting the YIG accurately on frequency.

It is useful, however, to program the YIG with 0000_{HEX} to turn off the current through the YIG tuning coil and thereby minimize the current consumption of the 1313B when the YIG is not in use.

Programming the YIG

To minimize hysteresis in the YIG, thus increasing its linearity and accuracy and enhancing the performance of the instrument, always step the YIG from lower frequencies to higher frequencies when approaching the final frequency. When it is necessary to tune the YIG to a lower frequency, use the following procedure:

1. Program the YIG to its lower limit (2.7 GHz – 2000_{HEX}).
2. Wait 50 milliseconds to allow the YIG to settle.
3. Program the YIG to the desired frequency.

NOTE

When the YIG is not in use, always program it to its lower limit (0000_{HEX}) to minimize power dissipation.



SECOND IF-GAIN CONTROL REGISTER (OFFSET + 20E_{HEX})

This register controls the second IF gain stage. This register is normally set for maximum gain.

IF Gain and Lowband Control Offset (Offset + 20E_{HEX})

Bit #	15	14	13	12	11	10	9	8	7	6	5	4	3	2	1	0
Write											16	8	4	2	1	.5
Read	Defined Below															

Bits 0-5

These bits control the Channel 1 second IF gain stage. A high state adds the amount of gain corresponding to that bit. For example, if bits 0 through 4 are high, and bit 5 is low, the gain is set to 15.5 dB.

Bit	Attenuation
0	= 0.5 dB
1	= 1 dB
2	= 2 dB
3	= 4 dB
4	= 8 dB
5	= 16 dB

Bits 6-15

Not used

IF FILTER FREQUENCY PLAN

Filter	Input IF (MHz)	LO 3 (MHz)	Output IF (CF, MHz)
50 kHz	249.4	228	21.4
500 kHz	249.4	228	21.4
2 MHz	249.4	228	21.4
8 MHz	249.4	228	21.4

LOCAL OSCILLATOR FREQUENCY PLAN

Three local oscillators are used with the 1313B Downconverter. These oscillators do not reside within the Downconverter. They are provided by a separate unit (Model 20309 or equivalent). This section outlines the frequency plan for the local oscillators to assist you in choosing the frequency of the local oscillators.

LOCAL OSCILLATOR 3 (LO 3)

This oscillator is not tunable and is set to a fixed frequency of 228 MHz.

LOCAL OSCILLATOR 2 (LO 2)

This oscillator is not tunable and is set to a fixed frequency of 3.25 GHz.

NOTE



LO 2 and LO 3 should be shut off when not in use. Refer to the Model 20309 manual.

LOCAL OSCILLATOR 1 (LO 1)

This oscillator is tunable from 3 GHz to 9 GHz in 1 Hz steps. It is essential that this oscillator is programmed to the appropriate frequency for each given input frequency and output IF mode. Use the formulas in the table below to calculate the frequency of this oscillator.

INPUT FREQUENCY (MODE)	IF 1 OUT (WIDE BAND)	IF 2 OUT (AUX IF)
1 MHz – 100 MHz LOW BAND BYPASS	LO 1 not used (Program to 3 GHz to save power)	Invalid mode
10 MHz – 2.9 GHz LOW BAND DOWNCONVERTED	Input frequency + 3.5 GHz	Input frequency + 3.4994 GHz
2.8 GHz – 8.75 GHz HIGH BAND (1st. HARMONIC)	Input frequency + 250 MHz	Input frequency + 249.4 MHz
8.75 GHz – 26.5 GHz HIGH BAND (3rd. HARMONIC)	$(\text{Input frequency} + 250 \text{ MHz})/3$	$(\text{Input frequency} + 249.4 \text{ MHz})/3$



This Page Intentionally Left Blank

7

CALIBRATION

INTRODUCTION

The Phase Matrix 1313B has four functions that require calibration:

1. IF Gain calibration
2. Attenuator calibration
3. YIG calibration
4. Aux IF calibration

This section provides suggested procedures for calibrating the 1313B for optimum performance.

CALIBRATION FILES

Since the 1313B does not have a processor or internal memory, all calibration data must be stored in the host computer and applied as offsets to the commands written to the 1313B control registers.

EQUIPMENT REQUIRED

- Local Oscillator, Phase Matrix 20309
- Synthesizer, Phase Matrix 1140B
- Spectrum Analyzer, HP 8566B
- Power Meter, HP 437 (two are required)
- Splitter, HP 11667C
- VXI chassis with controller (Slot 0 card)
- Host computer

Equivalent equipment may be substituted.



IF GAIN CALIBRATION

The IF Gain is calibrated to minimize power-measurement errors that can be caused by variations in gains and losses across the frequency spectrum. The 1313B is calibrated for an 8 dB gain from the RF input to the IF output with the internal step attenuator set to 30 dB (with the attenuation taken into consideration, the instrument's actual gain is 38 dB).

CALIBRATION PROCEDURE

Use the following instructions to manually calibrate the IF Gain or to develop an automatic calibration procedure:

1. Connect the equipment as shown in Figure 7-1 with a Power Meter connected to the 1313B IF1 output. The Spectrum Analyzer is not required in this procedure, but it may be desirable to observe and verify the integrity of the output signal.

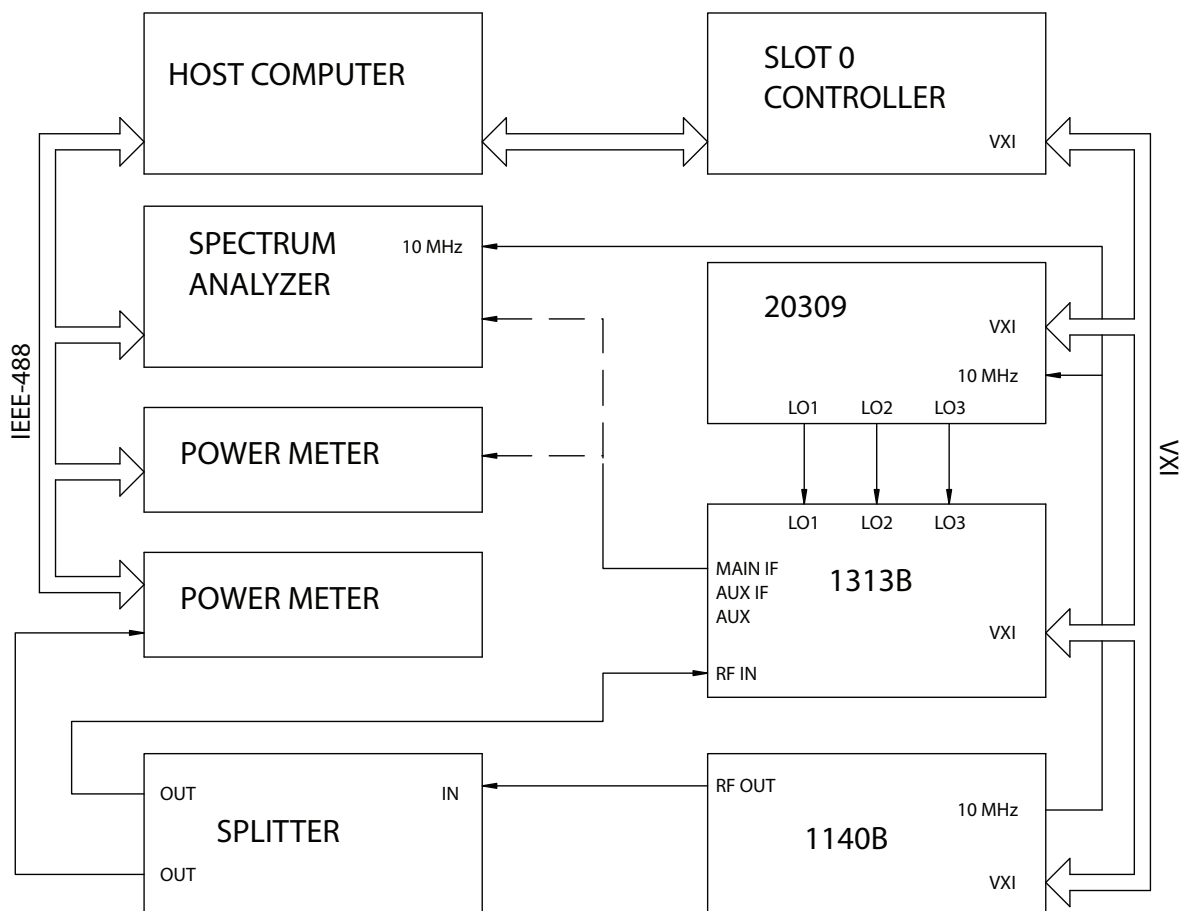

Figure 7-1. IF Gain Calibration Setup

2. Set the 1313B as follows:
 - A. YIG Off
 - B. RF Path appropriate to the frequency to be calibrated (IF Calibration is not applicable to the Bypass Path)
 - C. Output to Main IF (IF1)
 - D. Step Attenuator to 30 dB
3. Set the Synthesizer (Phase Matrix 1140B) as follows:
 - A. Frequency to the frequency of interest
 - B. Amplitude to -7 dBm (-10 dBm at the output of the splitter)
4. Set the Local Oscillator (Phase Matrix 20309) according to the Local Oscillator Frequency Plan on page 6-11.
5. Set the Spectrum Analyzer (HP 8566B) to 250 MHz.
6. Adjust the IF Attenuator (Bits 0 – 5 of the IF Gain and Low Band Control Register OFFSET + 200h) such as to produce, as close as possible, a gain of 8 dB (difference between the RF input amplitude and the IF output amplitude).
7. Record the resultant IF Attenuator setting in a calibration table indexed by frequency. Since the IF Attenuator is adjustable in 0.5 dB steps, the difference between the actual gain and the target gain (+8 dB) may also be recorded and applied as a correction factor in the digital signal processing when the downconverter is in use.
8. Repeat this procedure for each frequency step across the band of interest. Phase Matrix recommends calibrating the 1313B at 100 MHz steps.

ATTENUATOR CALIBRATION

Calibrating the attenuator minimizes power-measurement errors caused by variations from the nominal in attenuator loss across the frequency band. This procedure assumes the 1313B is already calibrated with the attenuator set to 30 dB.

A spectrum analyzer is connected to the IF1 output as the indicator, since power meters lack the dynamic range necessary to cover all attenuator settings. However, since the spectrum analyzer is not as accurate as the power meter in reading absolute power, its use should be confined to relative measurements taken with respect to the already calibrated 30 dB attenuator setting.

In planning the calibration routine, it is only necessary to develop a calibration table over the attenuation range required by the intended application of the 1313B. Attenuator settings which will not be used need not be calibrated.



CALIBRATION PROCEDURE

Use the following instructions to manually calibrate the Step Attenuator or to develop an automatic calibration procedure:

1. Connect the equipment as shown in Figure 7-1 (page 7-2) with a Spectrum Analyzer connected to the 1313B IF1 output.
2. Set the 1313B as follows:
 - A. YIG Off
 - B. RF Path appropriate to the frequency to be calibrated
 - C. Output to Main IF (IF1)
 - D. Step Attenuator to 30 dB
3. Set the Synthesizer (Phase Matrix 1140B) as follows:
 - A. Frequency to the frequency of interest
 - B. Amplitude to -7 dBm (-10 dBm at the splitter output)
4. Set the Local Oscillator (Phase Matrix 20309) according to the Local Oscillator Frequency Plan on page 6-11.
5. Set the Spectrum Analyzer (HP 8566B) to 250 MHz.
6. Adjust the IF Attenuator (Bits 0 – 5 of the IF Gain and Low Band Control Register OFFSET + 200h) to the value determined for the frequency in the IF Gain Calibration procedure on page 7-2.
7. Note the spectrum analyzer amplitude reading.
8. Increase the Step Attenuator setting 10 dB (to 40 dB). Record the difference between the spectrum analyzer reading and 10 dB less than the original spectrum analyzer reading. Repeat for 50, 60, and 70 dB.
9. Reduce the Synthesizer output level to -37 dBm (-40 dBm at the splitter output).
10. Set the Step Attenuator to 20 dB. Record the difference between the spectrum analyzer reading and 10 dB greater than the level noted in Step 7. Repeat for 10 and 0 dB.
11. Repeat this procedure for each frequency step across the band of interest.

YIG FILTER CALIBRATION

Calibrating the YIG filter is a two-stage operation. The first stage is a frequency calibration of the center of the YIG passband. The second part is an insertion-loss calibration. Each part is performed at each frequency step across the band at which the 1313B will be used in a YIG-filtered mode.

In actual operation of the 1313B, it is necessary to perform the required interpolation of the offsets determined herein for frequencies between the calibration points used in this procedure.

FREQUENCY CALIBRATION PROCEDURE

Use the following instructions to manually calibrate the YIG Filter or to develop an automatic calibration procedure to determine the offsets required to set the YIG Filter to a specific frequency:

1. Connect the equipment as shown in Figure 7-1 (page 7-2) with a Spectrum Analyzer (HP 8566B) connected to the 1313B IF1 output.
2. Set the 1313B as follows:
 - A. YIG Off
 - B. RF Path High Band
 - C. Output to Main IF (IF1)
 - D. Step Attenuator to 30 dB
3. Set the Synthesizer (Phase Matrix 1140B) as follows:
 - A. Frequency to the frequency of interest
 - B. Amplitude to -7 dBm (-10 dBm at the splitter output)
4. Set the Local Oscillator (Phase Matrix 20309) according to the Local Oscillator Frequency Plan on page 6-11.
5. Set the Spectrum Analyzer to 250 MHz.
6. Adjust the IF Attenuator (Bits 0 – 5 of the IF Gain and Low Band Control Register OFFSET + 200_{HEX}) to the value determined for the frequency in the IF Gain Calibration procedure on page 7-2.
7. Set a nominal value into the YIG Filter as follows:
 - A. Divide the frequency of interest by 411944 Hz
 - B. Convert the result to HEX (binary), and enter it into the YIG Control Register (OFFSET + 206_{HEX})
 - C. Turn the YIG Filter On
8. Note the spectrum analyzer amplitude reading.
9. Calculate a start value for the YIG Filter tuning routine which sets the YIG Filter to a nominal frequency 50 MHz below the frequency of interest, using the same routine described in Step 7.
10. Increase the number in the YIG Control Register one bit at a time, measuring the signal level after each increase, until the output rises to a level 6 dB below the level noted in Step 7. Note the HEX value in the YIG Control Register.
11. Increase the number in the YIG Control Register by 4Bh.



12. Continue to increase the number in the YIG Control Register one bit at a time, measuring the signal level after each increase, until the output drops to a level 6 dB below the level noted in Step 7. Note the HEX value in the YIG Control Register.
13. Compute the average of the values found in Steps 9 and 11. Record the result in the YIG Frequency Calibration Table.
14. Repeat for each frequency step across the band of interest.

AMPLITUDE CALIBRATION PROCEDURE

Use the following instructions to manually compensate for the YIG insertion loss or to develop an automatic calibration procedure:

1. Connect the equipment as shown in Fig. 5-1 with a Power Meter connected to the 1313B IF1 output. The Spectrum Analyzer is not used in the procedure.
2. Set the 1313B as follows:
 - A. YIG On
 - B. RF Path appropriate to the frequency to be calibrated (IF Calibration is not applicable to the Bypass Path)
 - C. Output to Main IF (IF1)
 - D. Step Attenuator to 30 dB
3. Set the Synthesizer (Phase Matrix 1140B) as follows:
 - A. Frequency to the frequency of interest
 - B. Amplitude to -7 dBm (-10 dBm at the output of the splitter)
4. Set the Local Oscillator (Phase Matrix 20309) according to the Local Oscillator Frequency Plan on page 6-11.
5. Set the YIG Control Register to the value determined in the YIG Frequency Calibration Procedure.
6. Adjust the IF Attenuator (Bits 0 – 5 of the IF Gain and Low Band Control Register OFFSET + 200h) to produce, as close as possible, a gain of 8 dB (difference between the RF input amplitude and the IF output amplitude).
7. Record the resultant IF Attenuator setting in a YIG calibration table indexed by frequency. Since the IF Attenuator is adjustable in 0.5 dB steps, the difference between the actual gain and the target gain (+8 dB) may also be recorded and applied as a correction factor in the digital signal processing when the downconverter is in use.
8. Repeat this procedure for each frequency step across the band of interest. Phase Matrix recommends calibrating the 1313B at 100 MHz steps.

AUXILIARY IF CALIBRATION PROCEDURE

Use the following instructions to manually compensate for the gain variation between the Main and Auxiliary IF (IF1 and IF2) or to develop an automatic calibration procedure:

1. Connect the equipment as shown in Fig. 5-1 with a Power Meter connected to the 1313B IF1 output. The Spectrum Analyzer is not used in the procedure.
2. Set the 1313B as follows:
 - A. YIG Off
 - B. RF Path to Low Band
 - C. Output to Auxiliary IF (IF2)
 - D. Step Attenuator to 30 dB
3. Set the Synthesizer (Phase Matrix 1140B) as follows:
 - A. Frequency to 2 GHz
 - B. Amplitude to -7 dBm (-10 dBm at the output of the splitter)
4. Set the Local Oscillator (Phase Matrix 20309) to 5.4994 GHz.
5. Adjust the IF Attenuator (Bits 0 – 5 of the IF Gain and Low Band Control Register OFFSET + 200h) to the value determined for the frequency in the IF Gain Calibration procedure on page 7-2.
6. Record the difference between the measured IF2 power and the IF1 power, adjusted for the calibration factor recorded in the IF Gain Calibration Procedure. Apply this IF2 calibration factor to all Low Band Auxiliary IF measurements.
7. Repeat this procedure with the following settings and apply this IF2 calibration factor to all High Band Auxiliary IF measurements at input frequencies below 8.75 GHz:
 - A. 1313B to High Band
 - B. 1140B Synthesizer to 5 GHz
 - C. 20309 Local Oscillator to 5.2494 GHz
8. Repeat this procedure with the following settings and apply this IF2 calibration factor to all High Band Auxiliary IF measurements at input frequencies above 8.75 GHz:
 - A. 1313B to High Band
 - B. 1140B Synthesizer to 10 GHz
 - C. 20309 Local Oscillator to 3.416467 GHz



This Page Intentionally Left Blank



VXIbus

INTRODUCTION

This VXIbus overview is from the VXIbus Specification, revision 1.3.

The goal of the VXIbus is to define a technically sound modular instrument standard based on the VMEbus that is open to all manufacturers and is compatible with present industry standards.

VXIbus is an acronym for VMEbus extensions for Instrumentation. The VXIbus specification details the technical requirements of VXIbus compatible components, such as mainframes, backplanes, power supplies, and modules. Before studying the VXIbus architecture, one should become familiar with the VMEbus and its specifications.

VMEbus BACKGROUND

The VMEbus is an open system architecture primarily focused at computer systems, though there presently is a limited offering of instrumentation. VMEbus modules are approximately six inches deep and come in two heights, about four and nine inches. The VXIbus specification refers to these as the A and B sizes, respectively. The precise dimensions are specified by the Eurocard standard, which describes a family of printed circuit boards and their associated DIN connector locations. VMEbus modules are designed for 0.8 inch slot to slot spacing. The A size board has a single 96 pin connector known as P1, while the B size may include a P1 and P2 connector. Each of these DIN connectors consists of three rows of 32 pins apiece on 0.1 inch centers. Typically, these boards are positioned vertically in a frame with the P1 connector closest to the top. Neither the VMEbus nor the VXIbus mandates a physical orientation, since orientation is only an implementation issue not needed for compatibility. Many VMEbus systems are designed to accept boards horizontally.

The VMEbus specification allows a maximum of 21 modules. However, if installed vertically in a mainframe intended for mounting in a standard 19 inch rack, 20 is the practical maximum. VMEbus makes no particular provision for an extension chassis or frame to frame communication. Multiple frame systems can be created by electrically buffering the VMEbus (at the loss of some bandwidth between cages) or by using standard data communication links that disguise the



underlying VMEbus architecture. There are no EMC (electromagnetic compatibility) requirements dictated by VMEbus, either conducted or radiated, nor are there power dissipation limits or chassis cooling requirements. VMEbus has left these issues to the system integrator, while VXIbus addresses these issues more rigorously.

Although electrically and logically similar to the 68000 microprocessor architecture, the VMEbus interface has been specified broadly enough that it is not dependent on any particular processor, and many processors are already supported on VMEbus, including the 80386. Many of the simpler VMEbus boards do not have processors at all.

A minimum VMEbus system requires only the P1 connector. All handshaking, arbitration, and interrupt support exists on P1, with P2 used to expand the system to 32 bits of address and data (A32 and D32). P1 will support 16 bit and 24 bit addressing (A16 and A24), as well as 8 and 16 bit data paths (D08 and D16). The extra lines needed for A32 and D32 are contained on the center row of P2, while the outer rows are user defined. These undefined pins are typically used for interface connections, such as allowing a module to drive a chassis mounted connector, access an internal disk drive, or provide for module to module communication. VSB (VMEbus Subsystem Bus) is a standard “subsystem bus” that has defined P2 as an additional communication path for up to six modules. Multiple VSBs may exist within any one VMEbus system. This is important to note, because VXIbus defines a subsystem of up to 13 modules and, like VSB, multiple VXIbus subsystems may exist within any one VXIbus system.

THE VXIbus EXTENSIONS

VXIbus retains P1 and the center row of P2 exactly as defined by VMEbus. This includes the 5 volt and æ12 volt power pins on P1, and the additional 5 volt pins on P2. VXIbus includes the A and B card sizes, and these modules remain totally VMEbus compatible. However, VXIbus has made substantial additions to the VMEbus specification oriented towards instrumentation that can best be described as an electromechanical superset and a logical subset.

VXIbus MODULES

VXIbus has added two Eurocard module sizes of about 13 inch depth referred to as the C and D sizes. These modules are 9 and 14 inches high respectively, and are placed on 1.2 inch centers. The C Eurocard is the same height as the VMEbus B size board, and may sport both the P1 and P2 connectors. The D size module is a triple high Eurocard that may include a P3 connector in addition to P1 and P2. The 1.2 inch module width allows feasible implementation of high density instrumentation modules while allowing enough space for shielding both sides of a module and inserting an optional chassis shield. It also has the added benefit of allowing a high degree of compatibility with the shorter and narrower A and B sizes by allowing them to be mounted on full length board carriers or adapters. These carriers/adapters may also shield the sides of standard VMEbus cards, giving them a high degree of electromagnetic compatibility with VXIbus systems.

VXIbus SUBSYSTEMS

A VXIbus system may have up to 256 devices, including one or more VXIbus subsystems. A VXIbus subsystem consists of a central timing module referred to as Slot 0 with up to 12 additional instrument modules. P2 and P3 are completely defined in a VXIbus subsystem. These 13 modules conveniently fill a standard 19 inch cabinet when mounted vertically on 1.2 inch centers. Many VXIbus systems will consist only of a single frame with these 13 modules. A common configuration will load the Slot 0 module with system resources such as the VXIbus mandated timing generation, the VMEbus required system controller functions, and a data communication port such as IEEE 488 or RS-232. Slot 0 may also include optional instrumentation. The other positions are general purpose slots for the user to mix and match modules. A single VXIbus subsystem may have less than 12 additional slots, but may not have more. Any combination of VXIbus subsystems may exist within a VXIbus system. For instance, one VXIbus system may consist of a frame with one Slot 0 and 12 VXIbus modules extended to another frame that has a Slot 0 adjacent to three instrument slots, another Slot 0 with five instrument slots, and four standard VMEbus slots of undefined P2.

P2 CONNECTOR DEFINITION

As mentioned previously, a VXIbus subsystem defines all P2 and P3 pins. The VXIbus P2 adds a 10 MHz ECL clock, ECL and analog supply voltages, ECL and TTL trigger lines, an analog summing bus, a module identification line, and a daisy chain structure known as the local bus. The trigger lines serve primarily as resources for signaling between instruments in a VXIbus subsystem, while the local bus lines are preferred for use within a multiple module instrument set (adjacent slots). The daisy chain local bus use is left to the module manufacturer to define, and several classes of electrical signals are permitted. Allowed signals are TTL, ECL, low voltage analog, and analog up to 42 volts. A keying mechanism near the faceplate indicating that module's local bus class prevents incompatible classes from accidentally being placed adjacently and potentially causing a destructive condition. Typical uses of the local bus include creating an internal analog bus or a chain of serial digital signal processors. There are a total of 24 local bus pins on P2, 12 lines in and 12 lines out for each slot; thus creating a 12 line bus that may or may not be passed on to adjacent slots.

P3 CONNECTOR DEFINITION

The VXIbus P3 connector adds many of the same resource types as described for P2, but is aimed at higher performance instrumentation. Included on P3 is a 100 MHz clock and sync signal, additional power pins of the same supply voltages, more ECL trigger lines, and 24 additional lines (48 pins) of daisy chain local bus. Also defined on P3 is a "star" trigger system where precision ECL trigger signals are routed through Slot 0 acting as a cross point switch. This allows very precisely matched trigger timing between modules regardless of module position.

VXIbus SYSTEM ARCHITECTURE

The VXIbus device protocols define how modules are granted non-conflicting portions of the VMEbus address space. A device is typically a single module, but this is not required. Several devices may exist on a single module, and a single device may consist of multiple modules. 256



devices may exist in any one VXIbus system, and are referred to by logical device address ranging from 0 to 255. A VXIbus system configuration space is defined in the upper 16K of the 64K A16 address space. Each device is granted a total of 64 bytes in this space, which is sufficient for many of the simpler devices. Devices requiring additional address space have their address requirements readable in a defined register in the A16 address space. A “resource manager” reads this value shortly after power-on, and then assigns the requested memory space by writing the module’s new VMEbus address into the device’s offset register. This method positions a device’s additional memory space in the A24 (16 Mbyte) or A32 (4 Gbyte) address space. If present day VMEbus cards are used in a system, the resource manager must position the VXIbus devices around the space taken by the standard VMEbus cards.

Higher level communication protocols are defined to allow sharing of interface modules and other devices by multiple manufacturers.

B

FUNCTIONAL BLOCK DIAGRAMS

FUNCTIONAL BLOCK DIAGRAMS

This section provides the functional block diagrams for the Phase Matrix 1313B VXIbus Microwave Downconverter.



This Page Intentionally Left Blank

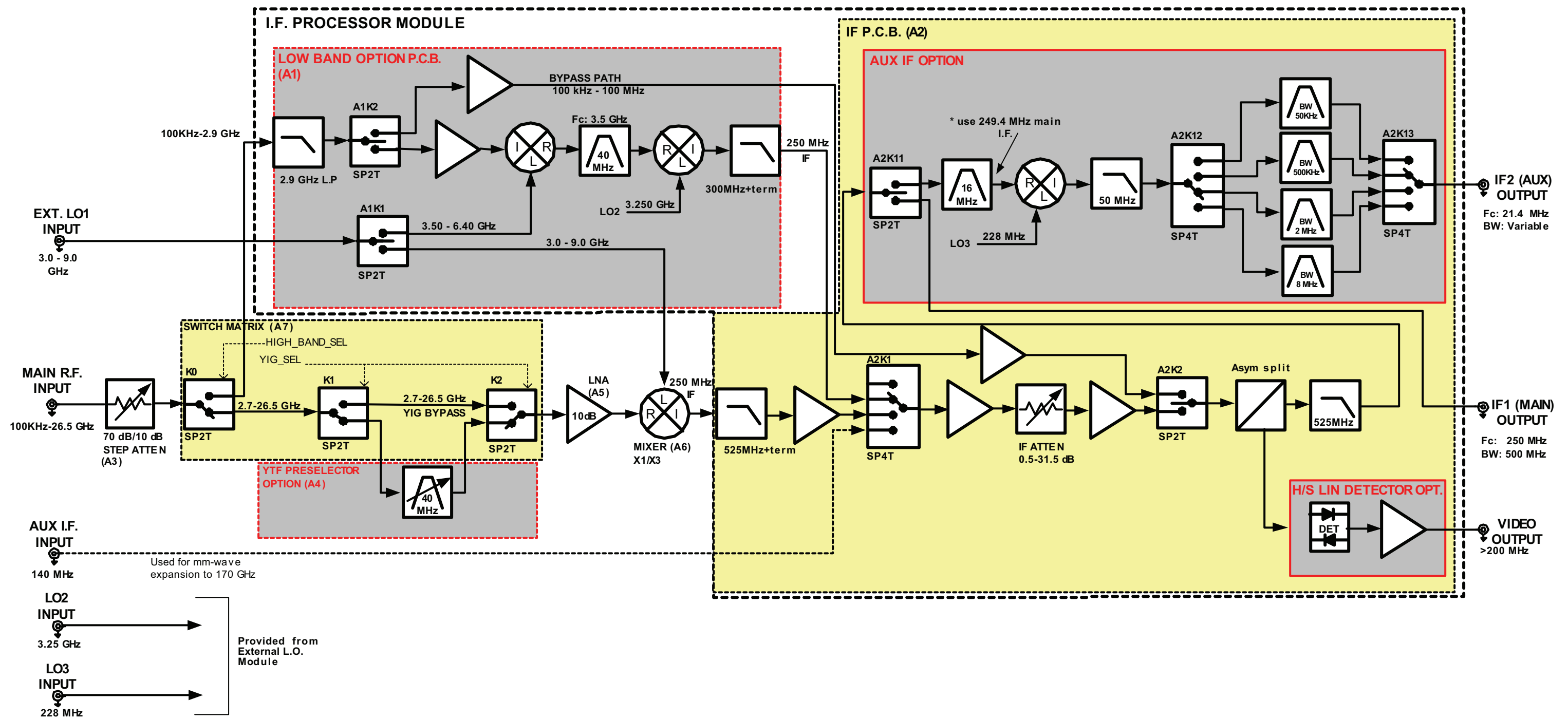

Figure A-1. Main Downconverter Block Diagram

This Page Intentionally Left Blank

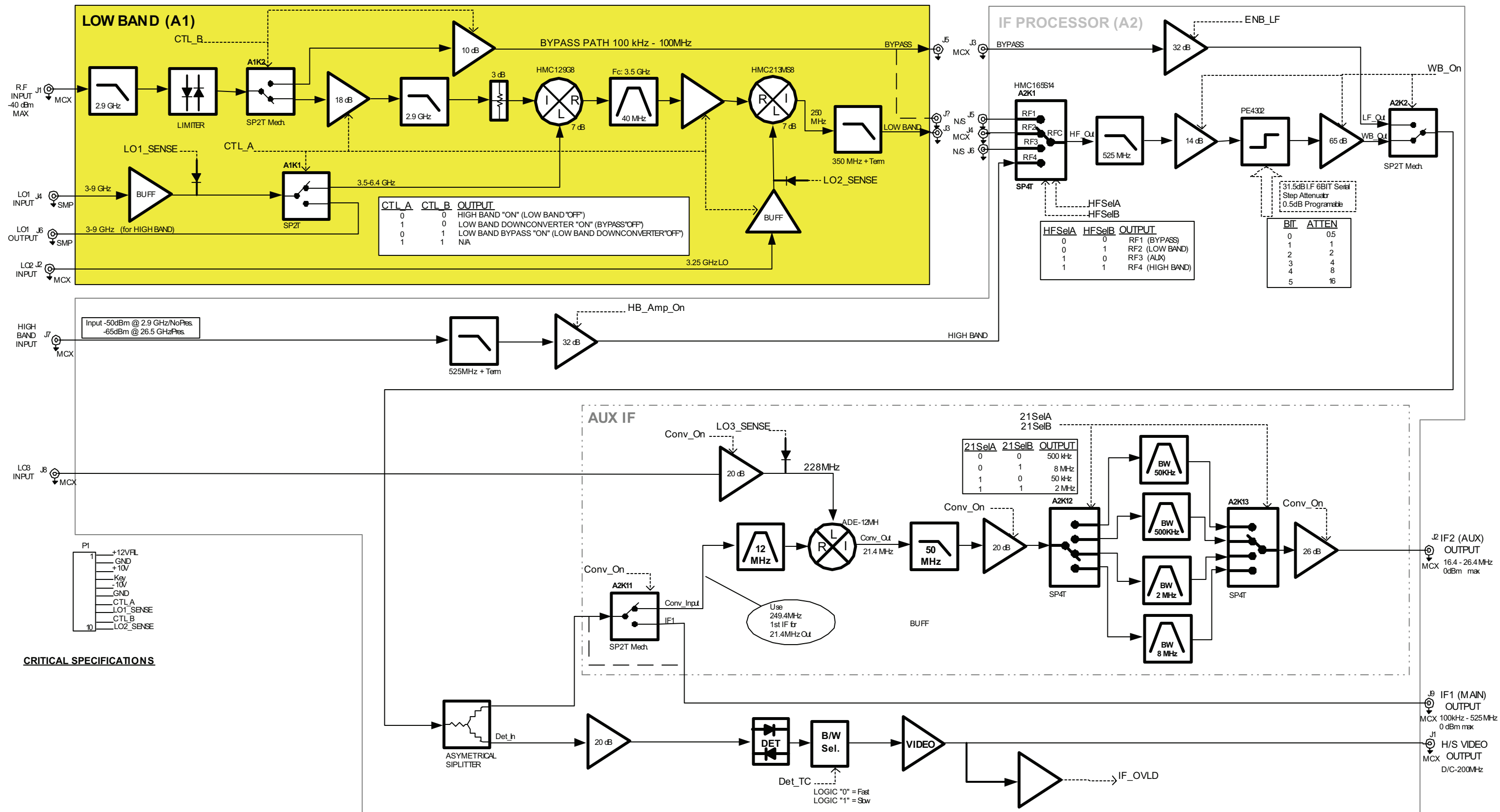

Figure A-2. Low-Band Module Block Diagram

This Page Intentionally Left Blank

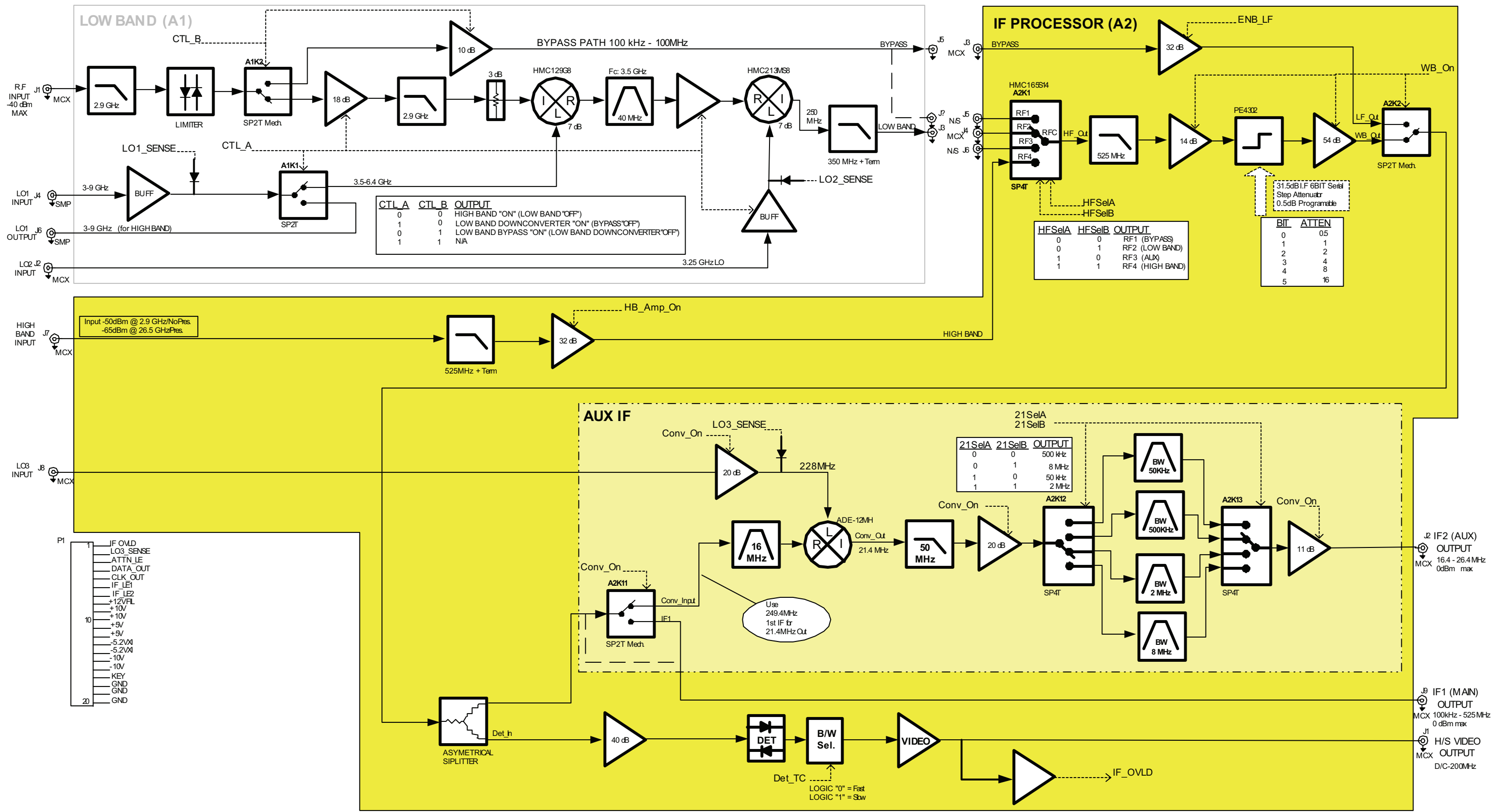

Figure A-3. IF Processor Module Block Diagram

This Page Intentionally Left Blank

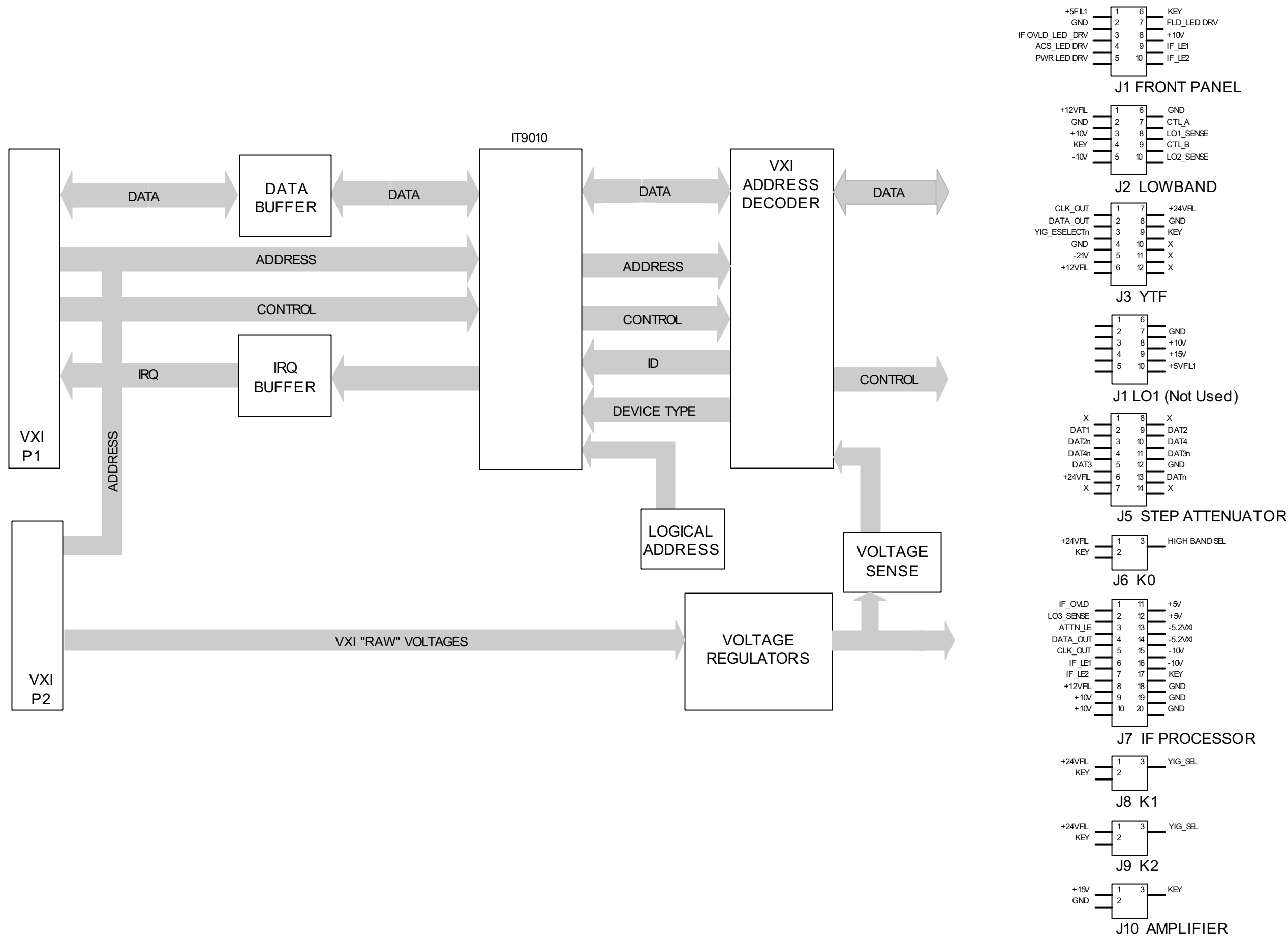

Figure A-4. VXI Interface Block Diagram

This Page Intentionally Left Blank